



www.impulse-fitness.kz

im impulse

Your Wellness Solution Provider



STRENGTH

impulse

EXOFORM

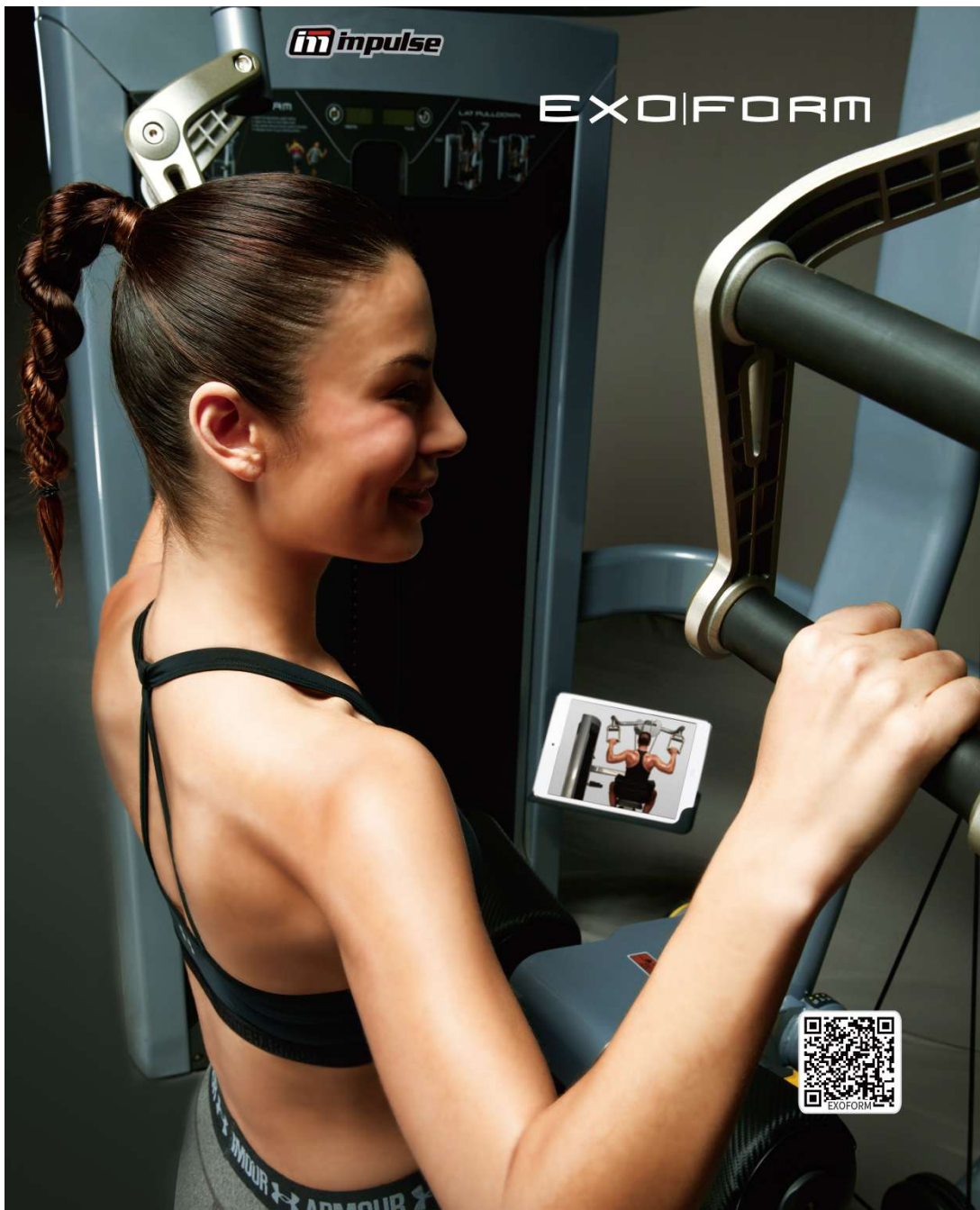

EXOFORM >>>

Uniformly low profile at 1492mm is designed by American team. Translucent shroud at thickness 3.2mm with smooth pattern is in injection molding, which designed elegantly and ensures ultra durability and non-deformation

Meet EN957 safety regulation

Build-in console, which is well designed by American UI team, displays reps and time

Ergonomically designed handle bars, which is patented, are with TPU material and aluminium grip ring. The concise design offers comfort and safety

The upright tubes are with special tube at size 72.8×141.7×3mm, and the functional part with race track tube at size 40×133×3mm. Tubes apply double powder-coated & painting process which ensure high-quality and ultra durability

Ergonomically designed upholstery is with PU foam which offers comfort and safety protection

The steel guide rod (diameter:19mm) is anti-corrosion coated and polished which ensures smoothly travel and rust-proof

Belt and cable driving system are both applied. Self-lubricate American Loss cable with nylon-coated 12 complex fiber ensures service life 300,000 times. The belt is with steel wire embedded which ensures ultra durability and long lifetime

Friendly designed iPad and bottle holders are separated to meet various requirement

With spiral spring assistance system, the patented 3-linkage seat adjustment is concisely designed, cost-saving and offers easy installment

The 5LBS incremental weight is to meet users requirement

All dynamic components are shielded for safety purpose

All the hardware parts exposed are nickel plated or stainless steel. The NBK bearing is applied

Gas spring for resetting



* WEIGHT STACK SOLD SEPARATELY

OPTION 1	160lbs/68.3kg
OPTION 2	200lbs/85.5kg
OPTION 3	235lbs/102.8kg
OPTION 4	295lbs/129.2kg



* COLOR OPTIONAL.



FE9701 CHEST PRESS

Dimension (L×W×H)	1230x1570x1490(mm) 48.4x61.8x58.7 (in)
Net Weight	169.7kg/373.3lbs



FE9702 LAT PULLDOWN

Dimension (L×W×H)	1304×1226×2109 (mm) 51.3x48.2x83.0 (in)
Net Weight	177.7kg/390.9lbs

FE9703 ARM CURL

Dimension (L×W×H)	1149x1567x1490(mm) 45.2x61.7x58.7 (in)
Net Weight	169.1kg/372lbs



FE9704 PECTORAL

Dimension (L×W×H)	1197x1551x1489 (mm) 47.1x61.1x58.6 (in)
Net Weight	166.2kg/365.6lbs

STRENGTH

EXOFORM



FE9705 LEG EXTENSION

Dimension (L×W×H)	1264x1239x1489 (mm) 49.8x48.8x58.6 (in)
Net Weight	169.6kg/373.1lbs



FE9708 ABDUCTOR/ADDUCTOR

Dimension (L×W×H)	1776x1546x1488 (mm) 69.9x60.9x58.6 (in)
Net Weight	165.8kg/364.8lbs



STRENGTH

EXOFORM



FE9706 SEATED LEG CURL

Dimension (L×W×H)	1240x1541x1489 (mm) 48.8x60.7x58.6 (in)
Net Weight	183.6kg/403.9lbs



FE9710 LEG PRESS

Dimension (L×W×H)	1781×1293×1491 (mm) 70.1x50.9x58.7 (in)
Net Weight	279kgs/613.8lbs

STRENGTH

EXOFORM



FE9712 SHOULDER PRESS

Dimension (L×W×H)	1762x1422x1492(mm) 69.4x55.9x58.7 (in)
Net Weight	168.7kg/371.1lbs



FE9714 ABDOMINAL

Dimension (L×W×H)	1383×1202×1491(mm) 54.4x47.3x58.7 (in)
Net Weight	141.5kg/311.3lbs



FE9715 PEC FLY/REAR DELT

Dimension (L×W×H)	1296x1758x1490(mm) 51x69.2x58.7 (in)
Net Weight	160.7kg/353.5lbs



FE9716 CALF RAISE

Dimension (L×W×H)	1265x1186x1721(mm) 49.8x46.7x67.8 (in)
Product Weight	167.8kg/369.2lbs



STRENGTH

EXOFORM



FE9718 TORSO ROTATION

Dimension (L×W×H)	1293x1346x1490 (mm) 50.9x53.0x58.7 (in)
Net Weight	176kg/387.2lbs



FE9720 WEIGHT ASSISTED CHIN/DIP COMBO

Dimension (L×W×H)	1750x1378x2197 (mm) 68.9x54.2x86.5 (in)
Net Weight	243.5kg/535.7lbs



FE9719 ROW

Dimension (L×W×H)	1996×1127×1492(mm) 78.6x44.4x58.7 (in)
Net Weight	174.8kg/384.6lbs



FE9721 PRONE LEG CURL

Dimension (L×W×H)	1606×1193×1492mm 63.2x47x58.7 (in)
Net Weight	154.2kg/339.2lbs

STRENGTH

EXOFORM



FE9723 TRICEP

Dimension (L×W×H)	1149x1580x1490 (mm) 45.2x62.2x58.7 (in)
Net Weight	163.5kg/359.7lbs



FE9724 LATERAL RAISE

Dimension (L×W×H)	1266x1261x1491 (mm) 49.8x49.6x58.7 (in)
Net Weight	187.5kg/412.5lbs



FE9726 GLUTE

Dimension (L×W×H)	1307x1483x1488 (mm) 53.9x58.4x58.6 (in)
Net Weight	168.5kg/370.7lbs



FE9732 BACK EXTENSION

Dimension (L×W×H)	1383×1203×1492(mm) 54.4x47.4x58.7 (in)
Net Weight	185.4kg/407.9lbs



STRENGTH

EXOFORM



IT95 Line >>>

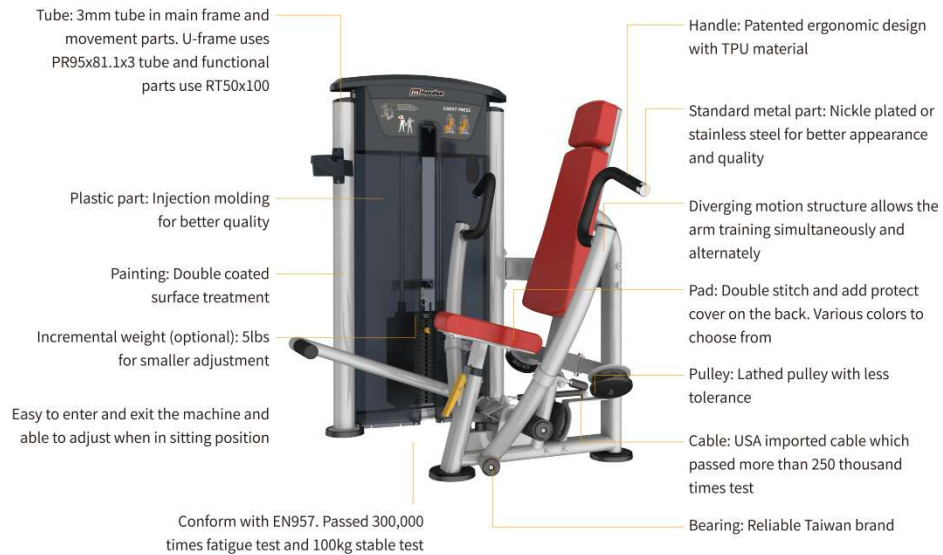

* WEIGHT STACK SOLD SEPARATELY

OPTION 1	160lbs/68.3kg
OPTION 2	200lbs/85.5kg
OPTION 3	235lbs/102.8kg
OPTION 4	295lbs/129.2kg



* COLOR OPTIONAL.
OPTIONAL FULL OR SMALL SHROUD.

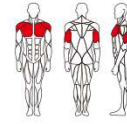

IT9501 CHEST PRESS

PRODUCT DIMENSION (LxWxH)	1475x1200x1506 (mm) 58.1x47.2x59.3 (in)
PRODUCT WEIGHT	127.4kg/280.3lbs

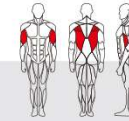

IT9502 LAT PULLDOWN

PRODUCT DIMENSION (LxWxH)	1440x1384x1889 (mm) 56.7x54.5x74.4 (in)
PRODUCT WEIGHT	147.7kg/324.9lbs

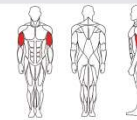

IT9503 ARM CURL

PRODUCT DIMENSION (LxWxH)	1310x1214x1506 (mm) 51.6x47.8x59.3 (in)
PRODUCT WEIGHT	115.5kg/254.1lbs



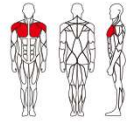

IT9504 PECTORAL

PRODUCT DIMENSION (LxWxH)	1500x1460x1506 (mm) 59.1x57.5x59.3 (in)
PRODUCT WEIGHT	145.2kg/320.1lbs

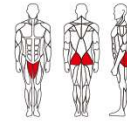

IT9508 ABDUCTOR/ADDUCTOR

PRODUCT DIMENSION (LxWxH)	1696x1560x1506 (mm) 66.8x61.4x59.3 (in)
PRODUCT WEIGHT	131.1kg/289.0lbs

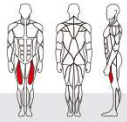

IT9505 LEG EXTENSION

PRODUCT DIMENSION (LxWxH)	1575x1189x1506 (mm) 62.0x46.8x59.3 (in)
PRODUCT WEIGHT	133.1kg/292.8lbs

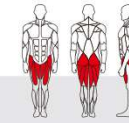

IT9509 TOTAL HIP

PRODUCT DIMENSION (LxWxH)	1300x980x1506 (mm) 51.2x38.6x59.3 (in)
PRODUCT WEIGHT	148.2kg/326.7lbs

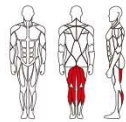

IT9506 SEATED LEG CURL

PRODUCT DIMENSION (LxWxH)	1536x1187x1489 (mm) 60.5x46.7x58.6 (in)
PRODUCT WEIGHT	149.6kg/329.1lbs

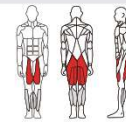

IT9510 LEG PRESS

PRODUCT DIMENSION (LxWxH)	1850x1150x1506 (mm) 72.9x45.3x59.3 (in)
PRODUCT WEIGHT	211.3kg/464.9lbs





IT9512 SHOULDER PRESS

PRODUCT DIMENSION	1565x1450x1506 (mm)
(LxWxH)	61.6x57.1x59.3 (in)
PRODUCT WEIGHT	137.4kg/302.3lbs

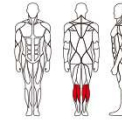

IT9516 CALF RAISE

PRODUCT DIMENSION	1289x1158x1715 (mm)
(LxWxH)	50.7x45.6x67.5 (in)
PRODUCT WEIGHT	120.2kg/265.0lbs

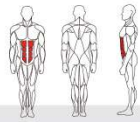

IT9514 ABDOMINAL

PRODUCT DIMENSION	1348x1168x1581 (mm)
(LxWxH)	53.1x46.0x62.2 (in)
PRODUCT WEIGHT	116.2kg/256.2lbs

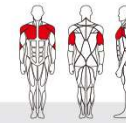

IT9517 SEATED DIP

PRODUCT DIMENSION	1794 × 1260 × 1506 (mm)
(LxWxH)	70.6x49.6x59.3 (in)
PRODUCT WEIGHT	142.5kg/313.5lbs

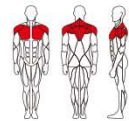

IT9515 PEC FLY/REAR DELT

PRODUCT DIMENSION	1302x1275x2048 (mm)
(LxWxH)	51.3x50.2x80.6 (in)
PRODUCT WEIGHT	132kg/291.0lbs

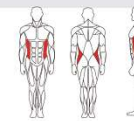

IT9518 TORSO ROTATION

PRODUCT DIMENSION	1221 × 1202 × 1506 (mm)
(LxWxH)	48.1x47.3x59.3 (in)
PRODUCT WEIGHT	150.8kg/331.8lbs



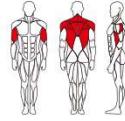

IT9519 VERTICAL ROW

PRODUCT DIMENSION (LxWxH)	1617×1264×1508(mm) 63.7x49.8x59.4 (in)
PRODUCT WEIGHT	126.5kg/278.3lbs

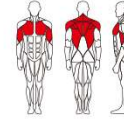

IT9522 LAT PULLDOWN/VERTICAL ROW

PRODUCT DIMENSION (LxWxH)	1900×900×2230(mm) 74.8x35.4x87.8 (in)
PRODUCT WEIGHT	120kg/264.6lbs

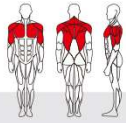

IT9520 WEIGHT ASSISTED CHIN/DIP COMBO

PRODUCT DIMENSION (LxWxH)	1573×1315×2286(mm) 61.9x51.8x90.0 (in)
PRODUCT WEIGHT	171kg/377.0lbs

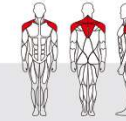

IT9524 LATERAL RAISE

PRODUCT DIMENSION (LxWxH)	1222x1213x1506 (mm) 48.1x47.8x59.3 (in)
PRODUCT WEIGHT	117.5kg/259.0lbs

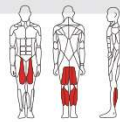

IT9521 PRONE LEG CURL

PRODUCT DIMENSION (LxWxH)	1443×1146×1506(mm) 56.8x45.1x59.3 (in)
PRODUCT WEIGHT	131.5kg/289.9lbs

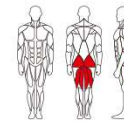

IT9526 GLUTE

PRODUCT DIMENSION (LxWxH)	1620x1230x1506 (mm) 63.8x48.4x59.3 (in)
PRODUCT WEIGHT	136.6kg/301.2lbs



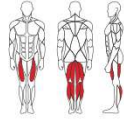

IT9528 LEG EXTENSION/LEG CURL

PRODUCT DIMENSION (LxWxH)	1350x1227x1506 (mm) 53.1x48.3x59.3 (in)
PRODUCT WEIGHT	167Kg/368.2lbs

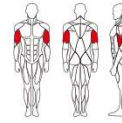

IT9533 BICEP CURL/TRICEP EXTENSION

PRODUCT DIMENSION (LxWxH)	1300x1225x1506(mm) 51.2x48.2x59.3(in)
PRODUCT WEIGHT	132.5kg/291.5lbs



IT9529 MULTI PRESS

PRODUCT DIMENSION (LxWxH)	1950x1460x1667 (mm) 76.8x57.5x65.6 (in)
PRODUCT WEIGHT	166kg/365.9lbs

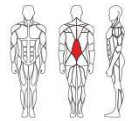

IT9532 BACK EXTENSION

PRODUCT DIMENSION (LxWxH)	1233x1185x1506 (mm) 48.5x46.7x59.3 (in)
PRODUCT WEIGHT	123.7kg/272.7lbs

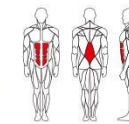

IT9534 ABDOMINAL/BACK EXTENSION

PRODUCT DIMENSION (LxWxH)	1208x1235x1506(mm) 47.6x48.6x59.3(in)
PRODUCT WEIGHT	135.2kg/298.1lbs





PL Line >>>

Easy to use, neat appearance, the PL line is a high quality dual/multi functional machines Light commercial/commercial series. This PL line is Impulse dual/multi functional line. The user-friendly design makes working out more simple, efficient, comfortable and satisfying.

Instructive - simple, step-by-step instructions and training tips help users get the most out of their exercise.

Aircraft spec 5mm American LOOS cable with a 2,000 lb breaking strength. End fittings tested to 250,000 cycles using full weight stack.

Easy-to-use, minimal adjustments and pre-stretch features allow for optimal exercise positions.

Glass fiber reinforced nylon pulleys with deep V-groove provides secure cable seating and fluid bearing rotation.

Compact - space efficient design requires minimal floor space.

Shroud is applied to protect the equipment or the possible injury during operation.

Tubing: 2.5 mm to 2.75mm. square tube differ into any types, from 30x60mm to 50x100mm, electro-welded to maximum integrity.

Pad total thickness is 70mm.



* WEIGHT STACK SOLD SEPARATELY

OPTION 1	170lbs/70.4kg
OPTION 2	250lbs/102.4kg

Color: metallic silver gray(Other colors are optional based on customer requirements)



PL9002
LAT PULLDOWN/SEATED ROW

PRODUCT DIMENSION (L×W×H)	1764×1019×2182 (mm) 69.4×40.1×85.9 (in)
PRODUCT WEIGHT	90.5 kg / 200 lbs
40'	136 Sets



PL9010
LEG PRESS/CALF RAISE

PRODUCT DIMENSION (L×W×H)	1938×1148×1520 (mm) 76.3×45.2×59.8 (in)
PRODUCT WEIGHT	111 kg / 245 lbs
40'	88 Sets



PL9021 MULTI PRESS

PRODUCT DIMENSION (L×W×H)	1924×1325×1518 (mm) 75.7×52.2×59.8 (in)
PRODUCT WEIGHT	111.5 kg / 246 lbs
40'	120 Sets



PL9022
REAR DELTOID/PECTORAL FLY

PRODUCT DIMENSION (L×W×H)	1362×1219×2061 (mm) 53.6×48.0×81.1 (in)
PRODUCT WEIGHT	107 kg / 236 lbs
40'	124 Sets



PL9016
OUTER/INNER THIGH

PRODUCT DIMENSION (L×W×H)	1609×722×1515 (mm) 63.3×28.4×59.6 (in)
PRODUCT WEIGHT	99 kg / 218 lbs
40'	130 Sets



PL9019
LEG EXTENSION/LEG CURL

PRODUCT DIMENSION (L×W×H)	1465×1245×1520 (mm) 57.7×49×59.8 (in)
PRODUCT WEIGHT	115.5 kg / 255 lbs
40'	75 Sets



PL9023 BICEPS/TRICEPS

PRODUCT DIMENSION (L×W×H)	1207×1164×1513 (mm) 47.5×45.8×59.6 (in)
PRODUCT WEIGHT	106 kg / 234 lbs
40'	115 Sets



PL9024 AB/LOW BACK

PRODUCT DIMENSION (L×W×H)	1044×1094×1520 (mm) 41.1×43.1×59.8 (in)
PRODUCT WEIGHT	99.5 kg / 219 lbs
40'	135 Sets



IF93 >>>

These simple, clean-lines, selectorized series specially designed for entry level small clubs and institutional applications. It offers a complete functional package, is inexpensive to own and is easy to maintain. It matches up beautifully with the benches and racks of the IF line.

- The clear and precise instructions and training tips are great for individuals who is new to strength training and help users to build targeted muscle .
- Ergonomic seat cushion, chest and back pad are made of polymer materials. The specially designed pads have different angles, which meet various training requirements.
- Specially designed cup holder is perfectly integrated with cage, making it simple and enorous.
- Ergonomically designed handle bars are made of TPV materials, which make your garb more comfortable and safety. It combines with aluminum end cap reflecting high-end taste.
- The upright tubing thickness of 2.5mm and the functional parts with rectangular tube at size of 50×100×2.5mm, which make IF93 stronger and more powerful.
- The main frame is coated with materials that environmental friendly, which helps to improve products quality and provide with good scratching and corrosion resistance.
- The translucent shroud with ABS materials (optional full shroud) is endurable and wear resisting. The main plastic parts are made using injection molding that help to provide teady quality.
- Designed with stainless steel seat adjustment that provides a longer service life, made it easy to adjust and look beautiful.
- The whole series are adopted with the equivalent cage height of 1530mm, which help to create a bright training environment of fitness club.
- All pulleys are adopted with high quality bearings which ensure smooth movement.



* WEIGHT STACK SOLD SEPARATELY

OPTION 1	160lbs/68.3kg
OPTION 2	200lbs/85.5kg
OPTION 3	235lbs/102.8kg
OPTION 4	295lbs/129.2kg



* THE FULL SHROUD IS OPTIONAL.
(Weight stacks varies by the shrouds)



IF9301 CHEST PRESS

PRODUCT DIMENSION (L×W×H)	1040×1360×1530 (mm) 40.5×53.5×60.2 (in)
PRODUCT WEIGHT	97.1kg



IF9302 LAT PULLDOWN

PRODUCT DIMENSION (L×W×H)	1585×1318×1891 (mm) 42.4×51.9×74.4 (in)
PRODUCT WEIGHT	100kg



IF9305 LEG EXTENSION

PRODUCT DIMENSION (L×W×H)	1146×1050×1530 (mm) 45.1×41.3×60.2 (in)
PRODUCT WEIGHT	101.5kg



IF9306 SEATED LEG CURL

PRODUCT DIMENSION (L×W×H)	1148×1034×1530 (mm) 45.2×40.7×60.2 (in)
PRODUCT WEIGHT	95kg



IF9303 ARM CURL

PRODUCT DIMENSION (L×W×H)	1216×1028×1530 (mm) 47.9×40.5×60.2 (in)
PRODUCT WEIGHT	90kg



IF9304 PECTORAL

PRODUCT DIMENSION (L×W×H)	1736×806×1530 (mm) 68.3×31.7×60.2 (in)
PRODUCT WEIGHT	95kg

* The right of specific weight to actual supply prevail.



IF9308 ABDUCTOR/ADDUCTOR

PRODUCT DIMENSION (L×W×H)	1570×935×1530 (mm) 61.8×36.8×60.2 (in)
PRODUCT WEIGHT	98.5kg



IF9310 LEG PRESS

PRODUCT DIMENSION (L×W×H)	1790×1168×1530 (mm) 70.5×46.0×60.2(in)
PRODUCT WEIGHT	120.5kg



IF9312 SHOULDER PRESS

PRODUCT DIMENSION (L×W×H)	1149×1456×1530 (mm) 45.2×57.3×60.2 (in)
PRODUCT WEIGHT	102.6kg



IF9315 PECTORAL

PRODUCT DIMENSION (L×W×H)	1420×1493×1863 (mm) 58.8×55.9×73.3 (in)
PRODUCT WEIGHT	90kg



IF9316 CALF RAISE

PRODUCT DIMENSION (L×W×H)	1150×1105×1775 (mm) 45.3×43.5×69.9(in)
PRODUCT WEIGHT	106kg



IF9314 ABDOMINAL

PRODUCT DIMENSION (L×W×H)	1304×1484×1490 (mm) 51.3×58.4×58.7 (in)
PRODUCT WEIGHT	89.5kg



IF9317 SEATED DIP

PRODUCT DIMENSION (L×W×H)	1227×1212×1530 (mm) 48.3×47.7×60.2(in)
PRODUCT WEIGHT	97.5kg



IF9318 TORSO ROTATION

PRODUCT DIMENSION (L×W×H)	1240×1105×1530 (mm) 48.8×43.5×60.2(in)
PRODUCT WEIGHT	96kg



IF9319 VERTICAL ROW

PRODUCT DIMENSION (L×W×H)	1818×870×1530 (mm) 71.6×34.3×60.2(in)
PRODUCT WEIGHT	91.5kg



IF9321 PRONE LEG CURL

PRODUCT DIMENSION (L×W×H)	1510×1150×1530 (mm) 59.4×45.3×60.2(in)
PRODUCT WEIGHT	101.5kg

IF9320
WEIGHT ASSISTED CHIN/DIP COMBO

PRODUCT DIMENSION (L×W×H)	1309×1256×2498 (mm) 51.5×49.4×98.3(in)
PRODUCT WEIGHT	107kg

IF9322
LAT PULLDOWN/VERTICAL ROW

PRODUCT DIMENSION (L×W×H)	1886×1223×2227 (mm) 74.2×48.1×87.7(in)
PRODUCT WEIGHT	90kg



IF9323 ARM EXTENSION

PRODUCT DIMENSION (L×W×H)	1079×1028×1530 (mm) 42.1×40.5×60.2 (in)
PRODUCT WEIGHT	91kg



IF9324 LATERAL RAISE

PRODUCT DIMENSION (L×W×H)	1179×750×1530 (mm) 46.4×29.5×60.2(in)
PRODUCT WEIGHT	85kg



IF9326 KICK BACK

PRODUCT DIMENSION (L×W×H)	1068×1034×1530 (mm) 42.0×40.7×60.2 (in)
PRODUCT WEIGHT	90kg



IF9328 LEG EXTENSION/LEG CURL

PRODUCT DIMENSION (L×W×H)	1272×1270×1530 (mm) 50.1×50.0×60.2 (in)
PRODUCT WEIGHT	105kg



IF9329 MULTI PRESS

PRODUCT DIMENSION (L×W×H)	2026×1446×1530 (mm) 79.8×56.9×60.2 (in)
PRODUCT WEIGHT	97.5kg

IF9333
BICEP CURL/TRICEP EXTENSION

PRODUCT DIMENSION (L×W×H)	1327×1203×1530 (mm) 52.2×47.4×60.2 (in)
PRODUCT WEIGHT	110kg



IF9334 AB/BACK

PRODUCT DIMENSION (L×W×H)	1592×1253×1531 (mm) 62.7×49.3×60.3 (in)
PRODUCT WEIGHT	TBD



IF9330 DUAL ADJUSTABLE PULLEY

PRODUCT DIMENSION (L×W×H)	1639×882×2270 (mm) 64.5×34.7×89.4 (in)
PRODUCT WEIGHT	117kg



IF9332 BACK EXTENSION

PRODUCT DIMENSION (L×W×H)	1120×1034×1530 (mm) 44.0×40.7×60.2 (in)
PRODUCT WEIGHT	98kg



IF9335 ABDUCTOR

PRODUCT DIMENSION (L×W×H)	1583×946×1530 (mm) 62.3×37.2×60.2 (in)
PRODUCT WEIGHT	95kg



IF9336 ADDUCTOR

PRODUCT DIMENSION (L×W×H)	1583×1036×1530 (mm) 62.3×40.8×60.2 (in)
PRODUCT WEIGHT	95kg

Jungle >>>



Multiple accessory racks enable user to put stuff and easy of access.

Shroud is made of translucent injection molding ABS which make the machine safer and good-looking.

Use dual-pulley for high rowing and low rowing. Increase diversity of motion.

Switch from high rowing to low rowing which accomodates different sizes of training field yet saving space either.



* WEIGHT STACK SOLD SEPARATELY

OPTION 1	160lbs/68.3kg
OPTION 2	200lbs/85.5kg
OPTION 3	235lbs/102.8kg
OPTION 4	295lbs/129.2kg

Larger distance between left and right upright accomodates a variety of users needs. No interference for users during exercise. (distance between sliding rail is 2680mm)

Multi-handle grips accomodate a variety of user training demands

Thanks to 1785mm sliderail, the hand grips could be adjusted from 1 to 36 degree. It helps to train almost total body muscle groups.

Use stainless steel roller tubing that prevent machine from wearing and corrosion.

Larger size of groundtubing strengthen stablization of machine

Perfect training placard enable detailed and professional guide to workout

Assistance handle bar: Easy hand grips help user keeping balance in exercise and enable more strength training.

Use 3.0mm thickness tube and spray powder coated. It has enhanced corrosion resistance and better appearance.

A roller type of pulley enables glide smooth and easy to adjust

The height of groundpads are adjustable which guarantees the stablization of machine.



* COLOR OPTIONAL.
OPTIONAL FULL OR SMALL SHROUD.



IT9525
ADJUSTABLE HI/LO PULLEY

PRODUCT DIMENSION (LxWxH)	1450x1245x2350(mm) 57.1x49.0x92.5(in)
PRODUCT WEIGHT	137.5kg/303.1lbs



IT9527
4 STACK MULTI-STATION

PRODUCT DIMENSION (LxWxH)	3489x1968x2382(mm) 137.4x77.5x93.8(in)
PRODUCT WEIGHT	308.7kg/680.6lbs



IT9525+IT9525+IT9527OPT

PRODUCT DIMENSION (LxWxH)	4196 × 1436 × 2360(mm) 165.2 × 56.5 × 92.9(in)
---------------------------	---



IT9530
DUAL ADJUSTABLE PULLEY

PRODUCT DIMENSION (LxWxH)	1620x1370x2270(mm) 63.8x54.0x59.4(in)
PRODUCT WEIGHT	195.5kg/431lbs



IT9527OPT
CABLE CROSSOVER-TRADITIONAL

PRODUCT DIMENSION (LxWxH)	2824x222x483(mm) 111.2x8.74x19.0(in)
PRODUCT WEIGHT	27.5kg/60.6lbs



IT9527+IT9527+IT9527OPT

PRODUCT DIMENSION (LxWxH)	5982 × 3489 × 2380(mm) 235.5 × 137.4 × 93.7(in)
---------------------------	--



IT9525+IT9527+IT9527OPT

PRODUCT DIMENSION (LxWxH)	5089 × 3489 × 2380(mm) 200.4 × 137.4 × 93.7(in)
---------------------------	--



IF9325 ADJUSTABLE HI / LO PULLEY

PRODUCT DIMENSION (L×W×H)	1449×1258×2338 (mm) 57.0×49.5×92.0 (in)
PRODUCT WEIGHT	96 kg / 212 lbs
40'	108 Sets



CABLE CROSSOVER IF9325+IF9325+IF9327OPT

PRODUCT DIMENSION (L×W×H)	4138x1448x2355(mm) 162.9x57.0x92.7(in)
------------------------------	---

IF9327 4 STACK MULTI-STATION

PRODUCT DIMENSION (L×W×H)	3450×2445×2338 (mm) 135.8×96.3×92.0 (in)
PRODUCT WEIGHT	258.6 kg / 570 lbs
40'	48 Sets



5 STACK MULTI-STATION IF9325+IF9327+IF9327OPT

PRODUCT DIMENSION (L×W×H)	5220x3428x2355(mm) 205.5x135.0x92.7(in)
------------------------------	--

• OPTIONAL FULL SHROUD VERSION.



IF9327OPT CABLE CROSSOVER-TRADITIONAL

PRODUCT DIMENSION (L×W×H)	2505×441×198 (mm) 98.6×17.4×7.8 (in)
PRODUCT WEIGHT	21.5 kg / 47 lbs
40'	526 Sets



8 STACK MULTI-STATION IF9327+IF9327+IF9327OPT

PRODUCT DIMENSION (L×W×H)	6262x3428x2355(mm) 246.5x135.0x92.7(in)
------------------------------	--

ES3000 3 STACK MULTI-STATION

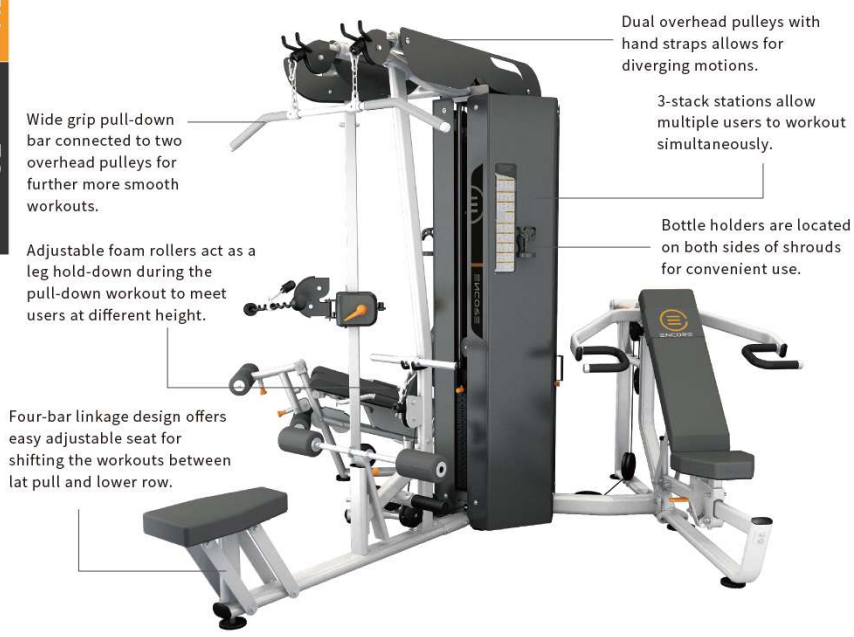

Wide grip pull-down bar connected to two overhead pulleys for further more smooth workouts.

Adjustable foam rollers act as a leg hold-down during the pull-down workout to meet users at different height.

Four-bar linkage design offers easy adjustable seat for shifting the workouts between lat pull and lower row.

Dual overhead pulleys with hand straps allows for diverging motions.

3-stack stations allow multiple users to workout simultaneously.

Bottle holders are located on both sides of shrouds for convenient use.

Product Dimension (L×W×H)	2694x2440x2148(mm) 106.1x96.1x84.6(in)
Product Weight	299.9kg/661.2lbs
Stacks Weight	91kgx3 (200lbsx3)
OPT Weight	26.5kg



ES3000 OPT HI-LO PULLEY ATTACHMENT

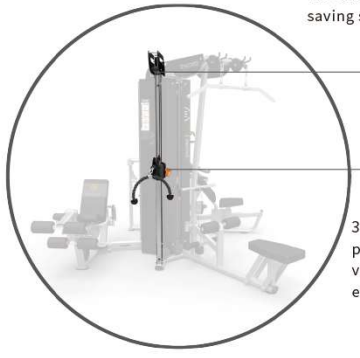

Quick installation, shares the stack with lat pull for saving space and cost.

31 vertical pulley positions for a large variety of different exercises.



Excellent structural design, easy & quick adjustment offers dynamic workout like chest press, incline press and shoulder press which meet various muscle groups training.



Adjustable handle is conveniently located for easy access.

Excellent structural design, easy & quick adjustment seat is for prone leg curls or leg extension exercises which satisfy various muscle groups.

ES9030 DUAL ADJUSTABLE PULLEY ES7011 BENCH



Chin-up/pull-up bar with ergonomic bends for regular grip, wide grip and reverse grip exercises.

31 vertical pulley positions for a large variety of different exercises.

With accessories as lat strap, long bar retractable strap, leg ext/curl strap and tricep rope, DAP offers users dynamic and various workouts.

Multi-position bench offers 5 upright/incline positions for back pad and 3 position for seat, which satisfies various workout experience.

The over-sized feet would stabilize the users during certain workouts like tricep extension.

Conveniently located iPad holder allows user to watch online training videos during the workouts, over-sized bottle holder is within reach.



Fold away bench for easy storage and space saving



ES9030(Long Shroud)

Product Dimension (L×W×H)	1734x1123x2150(mm) 68.3x44.2x84.7(in)
Product Weight	149.5kg/328.9lbs
Stacks Weight	77kgx2 (170lbsx2)



ES9030(Short Shroud)

Product Dimension (L×W×H)	1734x1123x2150(mm) 68.3x44.2x84.7(in)
Product Weight	121.5kg/267.3lbs
Stacks Weight	77kgx2 (170lbsx2)



ES7011

Product Dimension (L×W×H)	1440x525x490(mm) 56.7x20.7x19.3(in)
Product Weight	34.3kg/75.6lbs

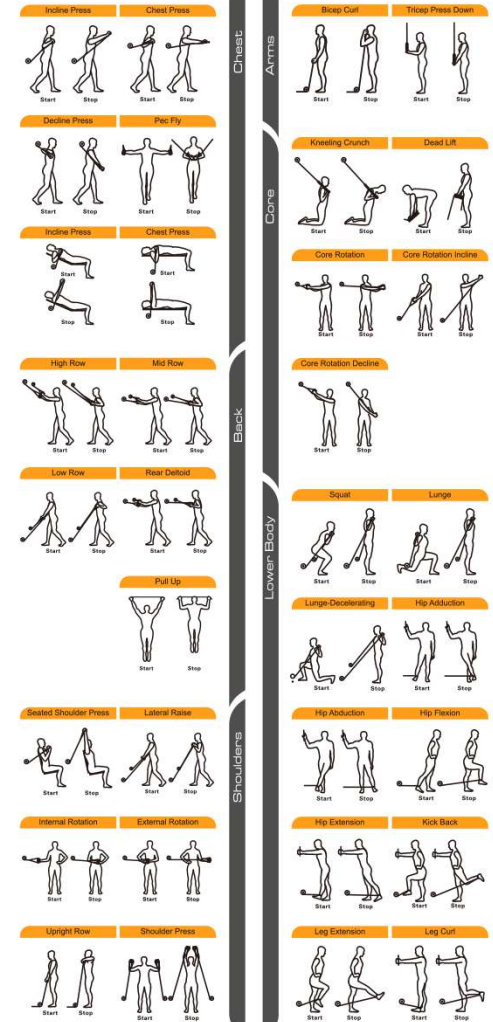

ES7030 DUAL ADJUSTABLE PULLEY



Chin-up/pull-up bar with ergonomic bends for regular grip, wide grip and reverse grip exercises.

31 vertical pulley positions for a large variety of different exercises.

With accessories as lat strap, long bar retractable strap, leg ext/curl strap and triceps rope, DAP offers users dynamic and various workouts.
*Accessories sold separately.



TENSION ROPE

Product Dimension	650(mm)/25.6(in)
Pull	≥450kg/992.1lbs



HANDLE

Product Dimension	1126x35(mm) 44.3x1.4(in)
-------------------	-----------------------------



ES7030

Product Dimension (L×W×H)	1641x916x2142(mm) 64.6x36.1x84.3(in)
Stacks Weight	77kgx2 (170lbsx2)

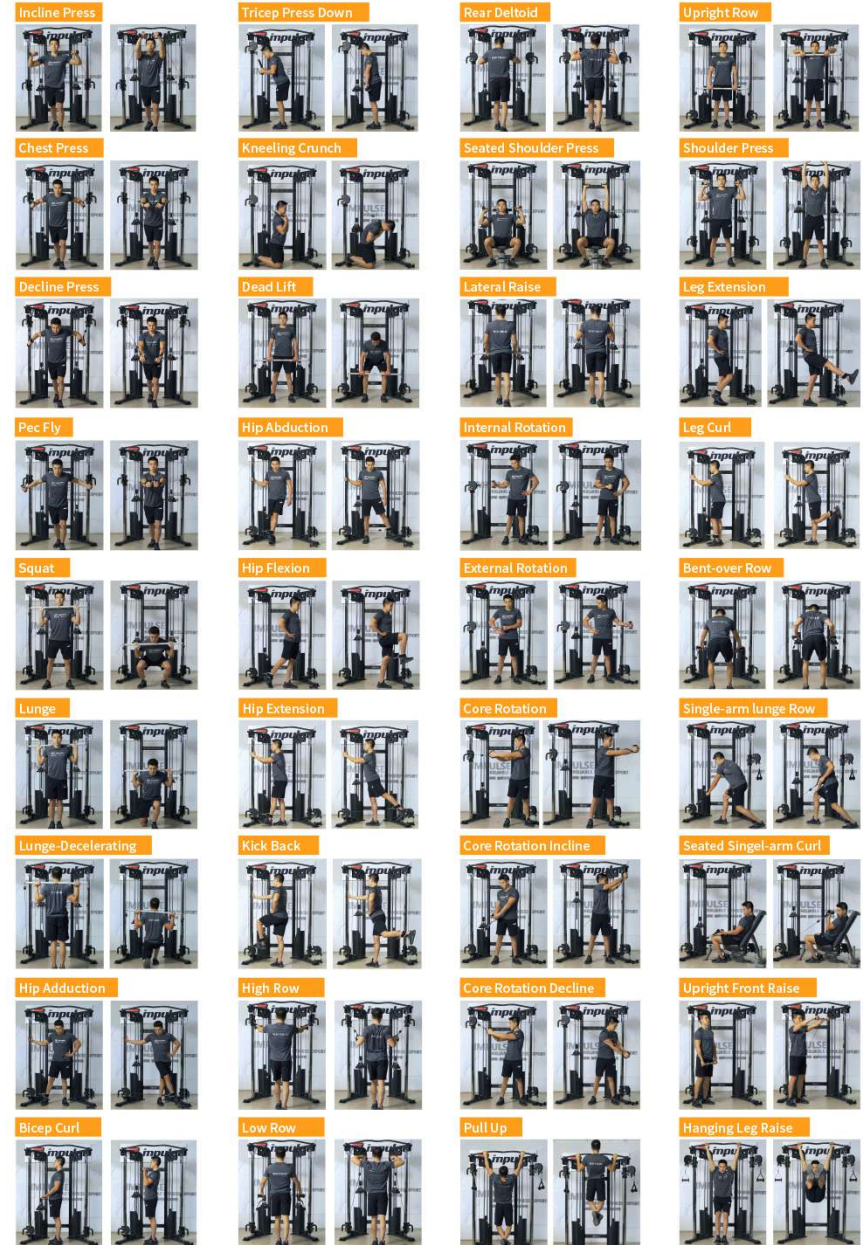

ES2100 Multi-Functional Trainer with Smith

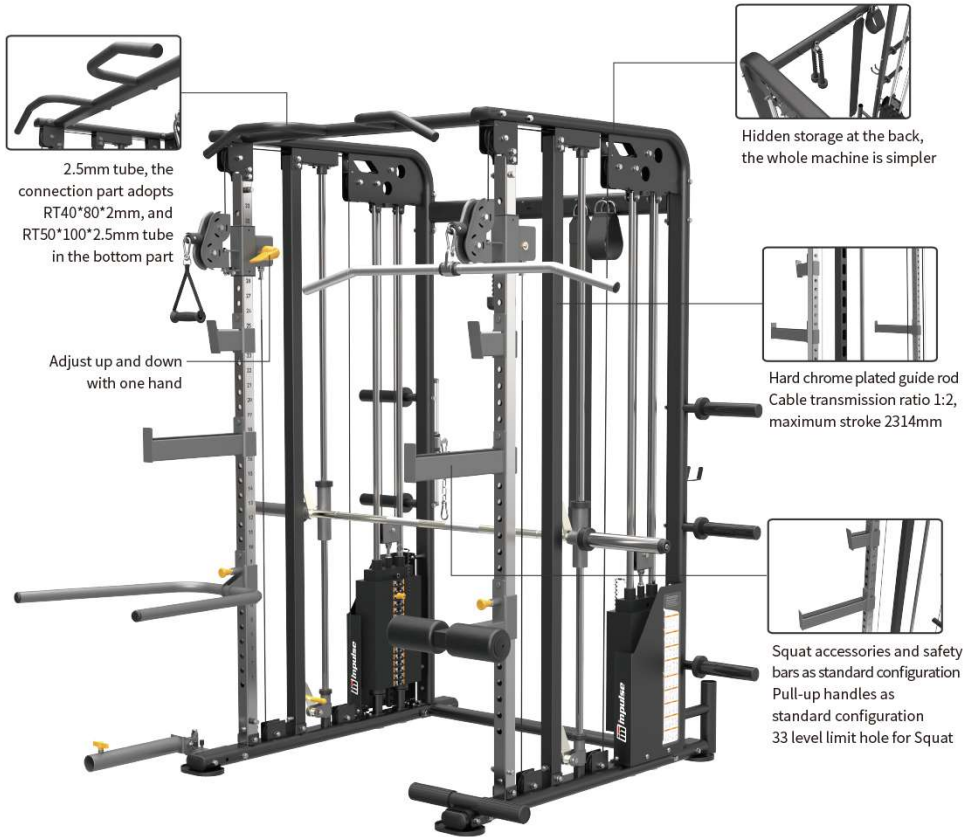

Product Dimension (L×W×H)	1681x1720x2090(mm) 66.18x67.72x82.28(in)
Product Weight	186.1kg/410.3lbs
Opt Weight Stack	170lbs/200lbs x 2 sets

ES2000 Multi-Functional Trainer with Smith (Plate Loaded)



Product Dimension (L×W×H)	2007x1724x2126(mm) 79.01x67.87x83.70(in)
Product Weight	184kg/405.7lbs

ES2000/2100 Accessory

Standard	POM Handle	Short Pole	Support Strap	Dip Arm
	Barbell Bar Storage	Ankle Strap	Double-ended Rope	Rowing Foot Pedal
Optional	ES2000OPT1 Pivot	ES2000OPT2 Foam Roller + Hi Pull-down Aluminum Rod		PTSHILO15000 Chop Bar

HSP-PRO001 AIR RESISTANCE DUAL-ARM FUNCTIONAL TRAINER



The 5 LED windows design can accurately display the resistance level, training times(2 windows), peak power percentage and parameters, which is convenient for the user to always grasp the training information to scientifically arrange the training plan



Depending on the height and movement of the trainer, the training arm can be adjusted in coronal plane (up and down) of 180° and at 13 gears. Unilateral horizontal level of both arms (front and rear) 90°, 7 gears adjustment, which is suitable for all heights and training types

Model	HSP-PRO001
Power	110V-220V
Resistance Range	2kg-25kg
Resistance Increment	0.1kg
Resistance Levels	25
Product Dimension	2500×1100×2400 (mm) 98.4×43.3×94.5 (in)
Net Weight	150kg/330.7lbs
Fixed	Can be fixed to the floor or wall



Equipped with double training arms, the cable joint end can rotate 360° with the change of force direction of the trainer, ensuring the comfort of the strength exertion and variable force direction need during the training process. Meanwhile, it can protect the cable and extend its service life



It can also expand a variety of accessories to cooperate with various special functional trainings, such as dual pull handle, ankle strap, training bat, training belt, thigh strap, tricep training rope, etc



Through easy-to-understand training guidelines, users can quickly master the training methods of major muscle groups



HSP-PRO002 AIR RESISTANCE FUNCTIONAL TRAINER



Accurate and convenient adjustment: it can adjust resistance at a minimum increment of 0.1kg with two buttons; giving user a better control over the functional training process



Through easy-to-understand training guidelines, users can quickly master the training methods of major muscle groups



The 50mm-2000mm single pulley track with 36 gears adjustment, and the angle of the pulley can be rotated with the change of the direction of the force, which meets all heights and training types of use, but also to protect the equipment and cable, extend the life of the role



Multiple HSP-PRO002 equipment can be designed as a training area to meet the needs of multi-functional training for single trainer or multi-group training

Model	HSP-PRO002
Power	110V-220V
Resistance Range	2kg-37.5kg
Resistance Increment	0.1kg
Resistance Levels	36
Product Dimension	560×445×2340 (mm) 22.0×17.5×92.1 (in)
Net Weight	150kg/330.7lbs
Fixed	Can be fixed to the floor or wall



CASES



CASES

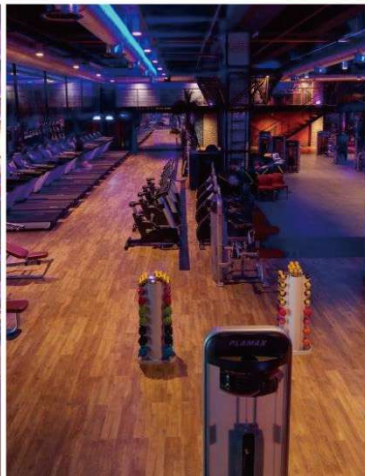



CASES



CASES



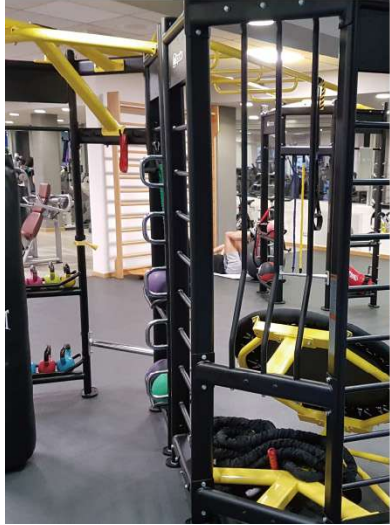

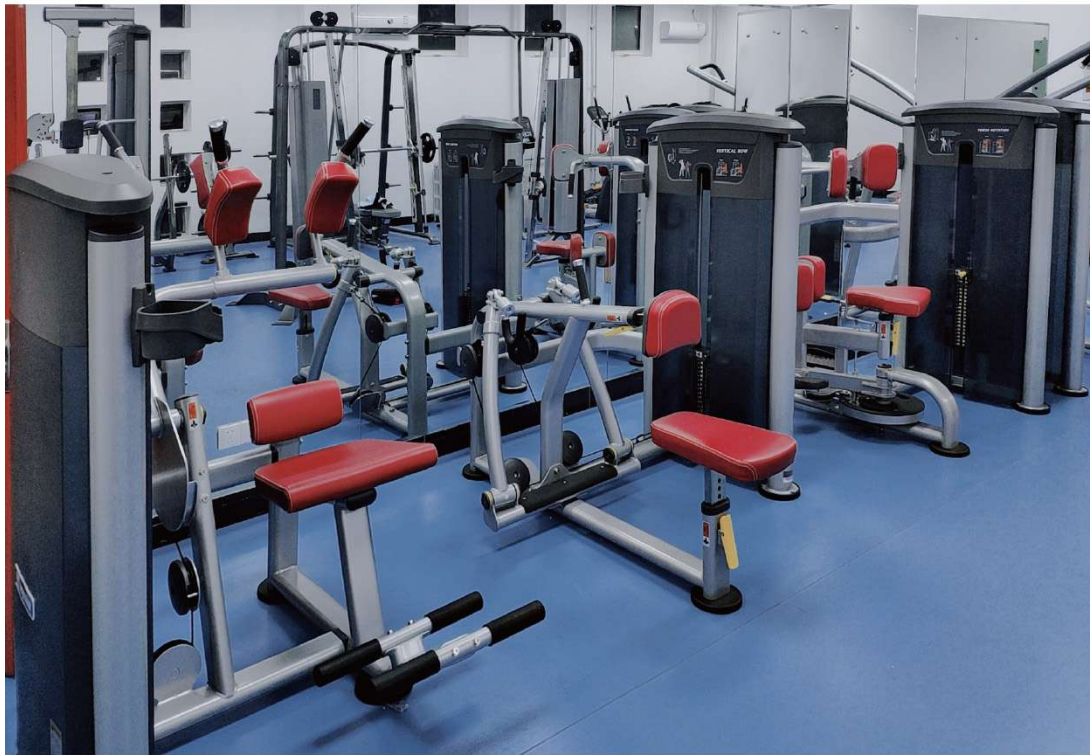



CASES



CASES



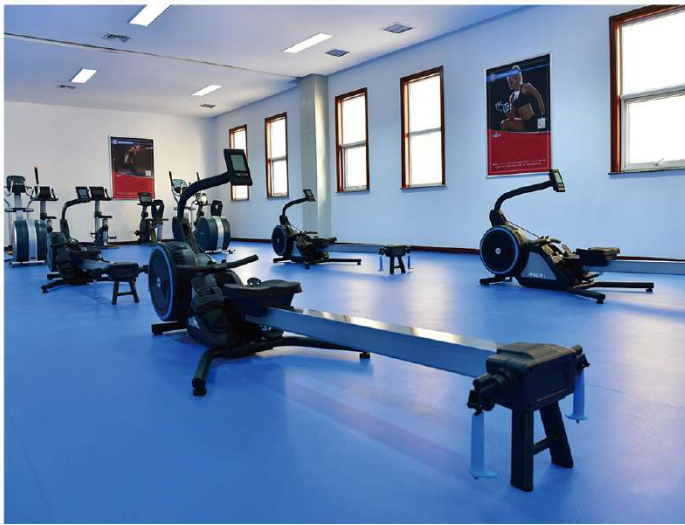
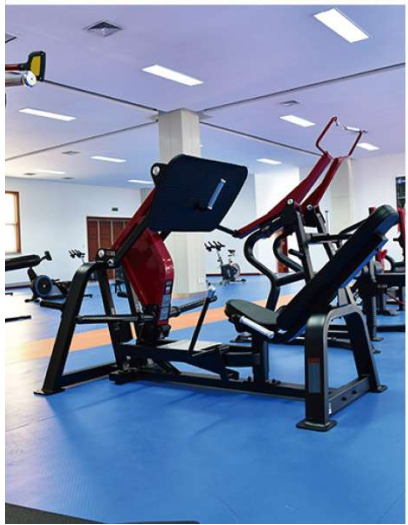

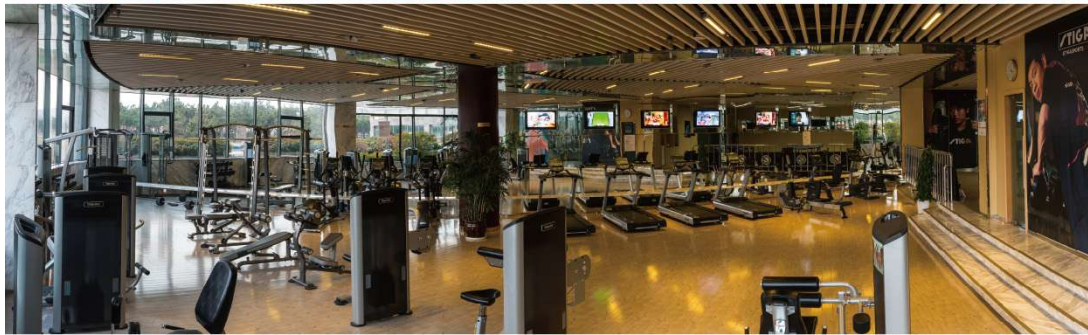
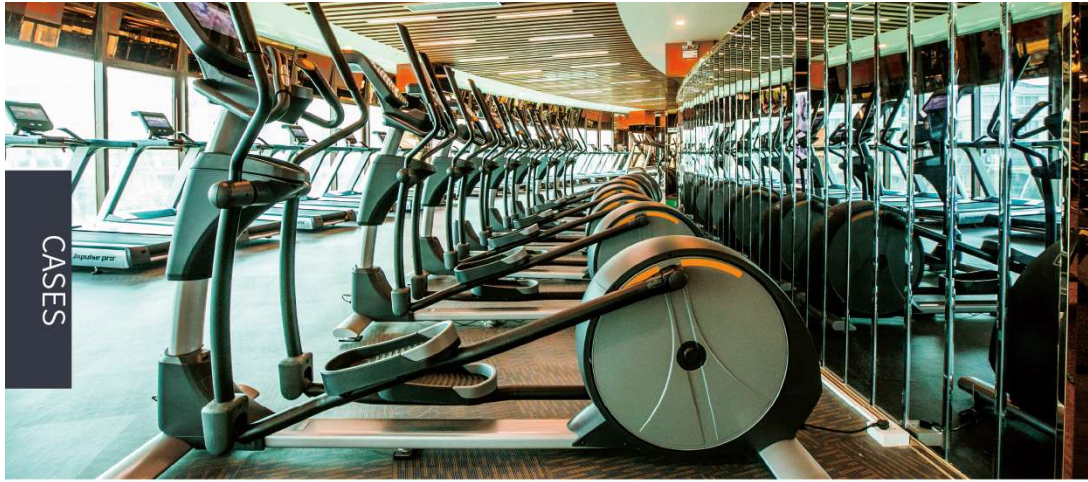

Impulse Cardiovascular Equipment Limited Warranty

Description	Warranty
Frame	7 Years
Treadmill AC Motor	3 Years
Treadmill DC Motor, Structural Moving Parts	2 Years
Display PCB, Motor Controller,	
Generator, EMS, ECB Brake	2 Years
Key Pad, Durable Wear Parts	1 Year

Impulse Strength Training Equipment Limited Warranty

Description	Warranty
Structural Steel Frame	Lifetime
Rotary Bearings, Weight Stacks, Pulleys,	
Guide Rods, Structural Moving Parts	2 Years
Cable, Linear Bearings, Springs	1 Year
Upholstery, Handgrips, All Other	
Items Not Listed	6 Months

* Conditions and Restrictions Applied.



m impulse

THE WAY TO WELLNESS

All text, picture and data in this catalogue are for reference only. If there is inconsistency between the information and the actual product, the actual product shall govern. Impulse reserves all rights to explain any error or difference in this catalogue.

The trademark property in copyright including "Siegling", "Wahoo" and "Polar" have been maintained in Impulse product catalogues belong to their respective trademark registers.

Statement: Impulse branding is upgrading and during that time, **m**, **Wahoo** and **impulse** are both trademarks of Impulse products. Thank you for your support as always.