

[www.impulse-fitness.kz](http://www.impulse-fitness.kz)

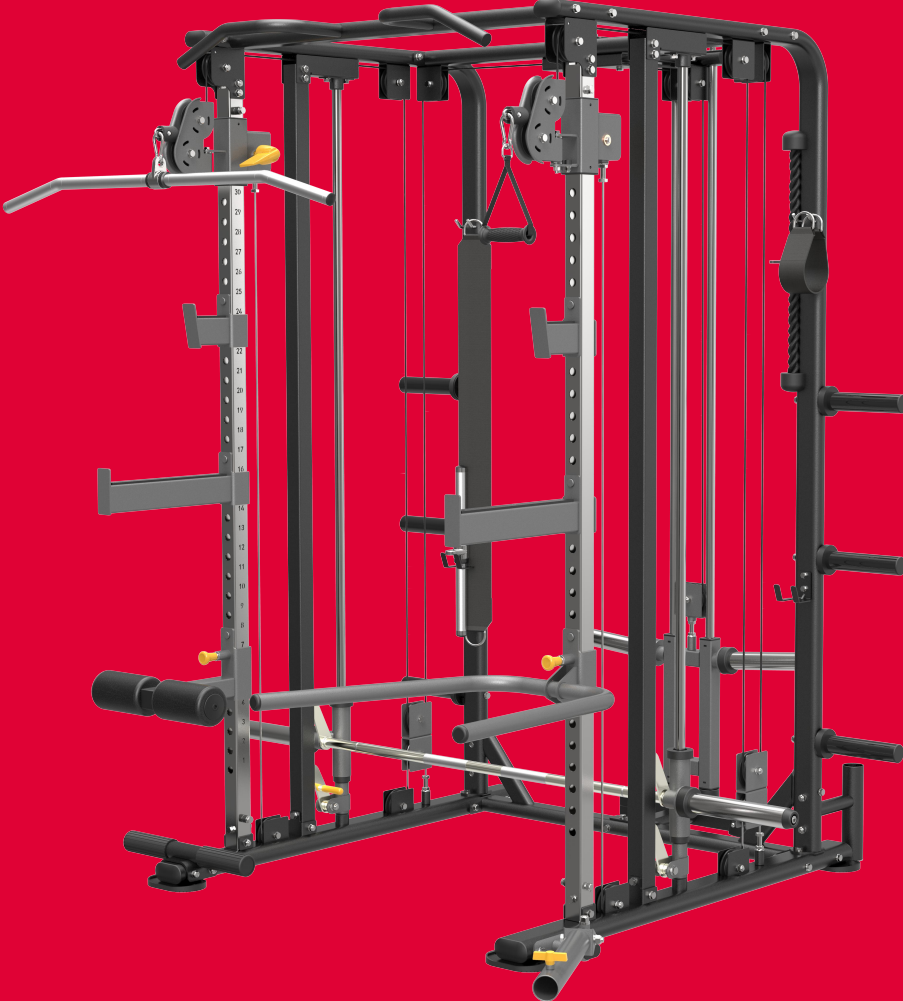

Your Wellness Solution Provider



Your Wellness Solution Provider



## INTRODUCTION

В начале 1990-х годов Impulse начала производство фитнес-оборудования. После почти 30 накоплений опыта. Марка Импульс была основана в 2004 году, уделяя особое внимание исследованиям, разработкам, производству и продаже фитнес-оборудования. В сентябре 2017 года. Impulse сделал IPO успешным на фондовом рынке Шэньчжэня. Он достиг прорыва на рынке капитала и принес больше финансовых поддержки R&D и производству рекомендуемых инструментов Imbulse. Мы предоставляем инновационные и высококачественные продукты для помещений и наружного использования, включая кардио-оборудование, силовое оборудование, функциональные тренировки и реабилитационные тренировки. также с интеллектуальными и инновационными продуктами для домашнего использования. Мы стремимся предоставлять желаемые продукты и услуги по искренней цене, и продукты были проданы в более чем 200 странах и регионах и создали глобальный маркетинг и послепродажные systems © Local backup on Impulse является ведущим поставщиком в отрасли здравоохранения. Новый индустриальный парк Impulse в стадии строительства. Первый этап проекта имеет общие инвестиции в размере 232 миллионов долларов США и общую площадь строительства 168,995,98 квадратных метров. Ожидается, что годовая стоимость проекта может состоять 620 миллионов долларов США после того, как проект достигнет полной мощности. Мы считаем, что доверие клиентов исходит из нашего стремления к совершенству продукта и изучения потребностей клиентов. Таким образом, Impulse будет продолжать следить за клиентом в первую очередь и качественным приоритетом, чтобы обслуживать наших бизнес партнеров и стать надежным экспертом по фитнесу, которому доверяют мировые клиенты.



● ECT7  
TREADMILL

● ECE5  
ELLIPTICAL

● ECR7  
RECUMBENT BIKE

● ECU7  
UPRIGHT BIKE

● ES3000  
3 STACK MULTI-STATION  
● ES3000 OPT  
HI-LO PULLEY ATTACHMENT

● ES9030  
DUAL ADJUSTABLE PULLEY  
● ES7011  
BENCH

# ENCORE

The Complete Series

Space Solutions for Corporate Fitness

## ECT7 TREADMILL



User-friendly console with keypad and scrolling LED window, multiple workout programs and unique heart rate zone programs



Built in bottle holders, accessories tray on both sides and display rack



Ergonomically designed handle bars with a towel rail



Bright orange colored saddle cover trim for step-on and step-off safety

Model	ECT7
Max User Weight	160kg/352lbs
AC/DC	AC
Power Requirement	15A
Electrical Receptacle & Plug	220-240V
Motor Power	3HP
Motor Peak Power	4.5HP
Speed range	1-20km/h (0.6-12mph)
Incline range	0 to 15%
One Touch Buttons	3%,6%,9%,12%(incline),3,6,9,12(Speed)
Handle bar Control	Yes
Console Display	6 window + dot Matrix
Console Readouts	Heart rate, Time Elapsed, Calories, Distance, Speed, incline, 1/4 mile or 400 meters motivational track
Metric/English	Metric&English
Touch Screen	No
Entertainment (TV, Wifi etc.)	No
Programs	Target, Manual, Cardio, Interval, Burn Calories, Heart Rate, 5K, Hill, Advanced
HR Monitor	Contact&Telemetry
Roller Diameter	Front:76mm/3" Back:63.8mm/2.5"
Deck	Reversable 1"deck
Running surface	508x1524(mm)/20"x 60"
Belt Thickness	2.5mm
Belt Brand	Siegling
Step-up Height	224mm
Suspension System	Pulflex™ Commercial Suspension System
Handle bar Control	Yes
Handle Folding	No
Accessory Storage	IPAD, Phone Holder, Magazine Holder, 2 Bottle Holders
USB Charger	No
USB Data Exchange	No
Fan	Yes (3 speed level)
Multi-language Display	No
Gross Weight	Box1: 183.6kg/403.9lbs Box2: 30.0kg/66.0lbs
Net Weight	Box1: 128.1kg/281.8lbs Box2: 22.1kg/48.6lbs
Product Dimension	2045×940×1453(mm)/80.5"×37.0"×57.2"
Packing Size	Box 1: 2215×850×475(mm) 87.2"×33.5"×18.7" Box 2: 1045×855×410(mm) 41.1"×33.7"×16.1"
40HQ	54Sets



## ECE5 ELLIPTICAL



User-friendly console with keypad and scrolling LED window, multiple workout programs and unique heart rate zone programs.



Multi grip ergo handles provide users of varying heights difference workout experiences.



Ergonomically correct pedals provide the ultimate natural motion.



User-friendly mini step allows users to step on and off from the rear.



Easy to service shroud design allows for convenient maintenance.



Model	ECE5
Certification	CE
Max User Weight	150kg/330lbs
Brake Type	Self Powered Hybrid Brake
Resistance Brake Power	350W
Resistance Levels	20 Levels
Electrical Receptacle & Plug	No
Incline range	No
Stride Length	508mm/20"
Pedal	Pedal with cushioned gel pads
Pedal Spacing	75mm/2.95"
Step-up Height	250mm/9.84"
One Touch Buttons	No
Handle bar Control	Yes
Console Display	6 LED windows + dot Matrix LED
Console Readouts	Speed, Time, Calorie, RPM, Distance, Heart rate, Resistance, etc.
Metric/English	Metric&English
Touch Screen	No
Entertainment (TV, Wifi etc.)	No
Programs	8 Preset, 4 Targets, 1 User
HR Monitor	Contact&Telemetry
Accessory Storage	Cup holder, Magazine Holder, Phone Holder
USB Charger	No
USB Data Exchange	No
Multi-language Display	No
Gross Weight	162.2kg/356.8lbs
Net Weight	119.6kg/263.1lbs
Product Dimension	1849×812×1800(mm)/72.8"×31.9"×70.9"
Packing Size	1150×765×1110(mm)/45.3"×30.1"×43.7"
40HQ	60Sets

## ECR7 RECUMBENT BIKE



User-friendly console with keypad and scrolling LED window, multiple workout programs and unique heart rate zone programs.

Step-through design allows users to step on and off bike easily.

Contoured and ventilated mesh seat back for improved comfort and enhanced air flow.

Easy to service shroud design allows for convenient maintenance.

Unique storage pocket under the seat for stowing larger personal belongings such as magazines.

Wrap-around (colored) seat adjustment handle for quick and easy seat adjustments.



Model	ECR7
Certification	CE
Max User Weight	150kg/330lbs
Brake Type	Self-generating
Resistance Brake Power	300W
Resistance Levels	20
Crank	Standard
Pedal	Weighted pedal with skate-style clip
Flywheel Weight	8kg
One Touch Buttons	No
Handle bar Control	Ergonomically designed seat-side handles with contact heart rate
Console Display	6 LED windows + dot Matrix LED
Console Readouts	Speed, Time, Calorie, RPM, Distance, Heart rate, Resistance, etc.
Metric/English	Metric&English
Touch Screen	No
Entertainment (TV, Wifi etc.)	No
Programs	12
HR Monitor	Contact&Telemetry
Accessory Storage	Yes
USB Charger	No
USB Data Exchange	No
Multi-language Display	No
Special Features	On-your-finger-tips, ergonomically designed handle bars, two-sided pedals, k-o-p-s biomechanics, easy to service
Gross Weight	100.7kg / 221.5lbs
Net Weight	83.2kg/183.0lbs
Product Dimension	1670×634×1326(mm)/65.7"×25.0"×52.2"
Packing Size	1775×445×730(mm)/70.0"×17.5"×28.7"
40GP	96Sets



User-friendly console with keypad and scrolling LED window, multiple workout programs and unique heart rate zone programs.



Multiple riding grip positions are fitted with two sets of heart-rate reception, which provides users different workout experience. Bright colored fingertip controls for changing resistance for easy adjustments throughout the workout.



Dual oversized water bottle holders and mobile phone pocket conveniently located for those long bike rides.



Ergonomic single-hand seat adjustment makes easy to find the right position.



Easy to service shroud design allows for convenient maintenance.



## ECU7 UPRIGHT BIKE



Model	ECU7
Certification	CE
Max User Weight	150kg/330lbs
Brake Type	Self-generating
Resistance Brake Power	300W
Resistance Levels	20
Crank	Standard
Pedal	Weighted pedal with skate-style clip
Flywheel Weight	8kg
One Touch Buttons	No
Handle bar Control	3 riding positions , with contact heart rate grips
Console Display	6 LED windows +dot Matrix LED
Console Readouts	Speed, Time, Calorie, RPM, Distance, Heart rate, Resistance, etc.
Metric/English	Metric&English
Touch Screen	No
Entertainment (TV, Wifi etc.)	No
Programs	12
HR Monitor	Contact&Telemetry
Accessory Storage	Yes
USB Charger	No
USB Data Exchange	No
Multi-language Display	No
Special Features	On-your-finger-tips, ergonomically designed handle bars, two-sided pedals, k-o-p-s biomechanics, easy to service
Gross Weight	78.5kg/172.7lbs
Net Weight	67.4kg/148.3lbs
Product Dimension	1132×628×1478(mm)/ 44.6"×24.7"×58.2"
Packing Size	1155×445×730(mm)/ 45.5"×17.5"×28.8"
40GP	156Sets

# FGT300 TREADMILL

CARDIO

FG



Power-off State

**Concealed Capacitive Touch LED Mirror Screen**  
Featuring a concealed capacitive touch button design for responsive and pressure-free interactions, enhancing product longevity. The screen, in its powered-off state, seamlessly blends into a unified black mirror surface, elevating the overall aesthetic appeal.

15W Wireless Charging



**Smart Knob**  
Press to start, rotate left for deceleration/right for acceleration, short press to pause, long press to stop. Additionally, quick adjustments can be made during parameter settings.



**Bottom-mounted Motor Design**  
Utilizing a bottom-mounted motor design, the running belt seamlessly extends across the entire deck, significantly enhancing belt utilization. This innovative approach increases the running space by 20%, providing an expansive 520mm × 1700mm area for an unobstructed and enjoyable running experience.

Model	FGT300
Max User Weight	150kg
Power Requirement	220V/10A
Motor Power	2.5HP
Motor Peak Power	5.0HP
Speed Range	0.5-18km/h
Incline Range	0-15% (15 levels)
Suspension System	10-Point Full Deck Suspension System
Console	5 LED windows +16×32 Matrix
Console Readouts	Speed, Incline, Time, Distance, Calories, HR
HR Monitor	Contact
Quick Button	8 Direct Speed Selection Buttons
Preset Program	24
Target Program	3
Custom Program	3
Fit Test Program	1
Charging Unit	Wireless
Accessory Storage	Pad Phone Holder/Bottle Holder
Product Dimension	1856 × 811 × 1546mm/73.1 × 31.9 × 60.9(in)
Packing Dimension	2230 × 910 × 450mm/87.8 × 35.8 × 17.7(in)
Running Surface	520 × 1700mm/20.5 × 66.9(in)
Net Weight	115kg/253.5lbs
Gross Weight	133kg/293.2lbs
Deck Thickness	20mm
Belt Thickness	1.8mm

CARDIO

FG



## FGE300 ELLIPTICAL



### Concealed Capacitive Touch LED Mirror Screen

Featuring a concealed capacitive touch button design for responsive and pressure-free interactions, enhancing product longevity. The screen, in its powered-off state, seamlessly blends into a unified black mirror surface, elevating the overall aesthetic appeal.



Powered-off State

### Ease of Maintenance

Featuring a concealed maintenance port design, simply open the hidden cover to access and maintain the core components, reducing maintenance costs.



Concealed Maintenance Port



### Convenient Fingertip Control System

Featuring both fixed and dynamic training dual-position handlebar design, allowing free selection of handlebar positions based on different training modes.

The fixed handlebar position includes a resistance adjustment button for quick intensity customization.

### 250W Self-Generating Electromagnetic Resistance System + 32-Level Resistance Adjustment

- 250W Self-Generating Resistance System: Satisfy high-intensity training needs; the self-generating system is environmentally friendly, eliminating the need for external power sources, providing flexibility in placement without being constrained by power outlet locations.
- 32-Level Fine-tuned Resistance Levels: Precise resistance adjustment for smooth transitions, coupled with various training modes to meet diverse training requirements.

Model	FGE300
Console	4 LED Windows+8*20 Matrix
Program	12 Preset Programs, 5 Custom Programs (U0-U4), 1 Constant Power Program, 4 HR Programs, 5 Target Programs (Time, Distance, Calories, Power, HR), 1 HR Recovery Test
Console Readouts	Speed, RPM, Distance, Calories, Power, Time, Resistance Level, HR
Power Requirement	Self-generating
Resistance	32 Levels Electromagnetic Resistance System, 250W
Flywheel	10.8kg ( Self-generating Module )
Stride Length	20"(508mm)
Pedal Distance	255mm
Step-up Height	330mm
Sliding Rail	4
HR Monitor	Contact
Quick Button	6 Direct Resistance Selection Buttons + Fingertip Control System
Product Dimension	1750×630×1900mm/68.9×24.8×74.8(in)
Packing Dimension	1840×560×825mm/72.4×22.0×32.5(in)
Max User Weight	150kg/330.7lbs
Net Weight	115kg/253.5lbs
Gross Weight	133kg/293.2lbs

## ES3000 3 STACK MULTI-STATION

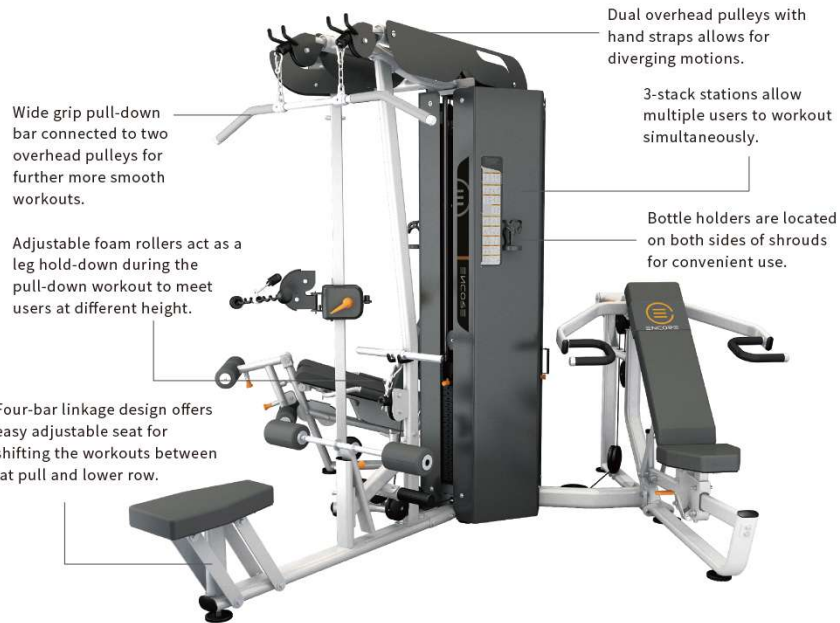

Product Dimension (L×W×H)	2694x2440x2148(mm) 106.1x96.1x84.6(in)
Product Weight	299.9kg/661.2lbs
Stacks Weight	91kgx3 (200lbsx3)
OPT Weight	26.5kg



## ES3000 OPT HI-LO PULLEY ATTACHMENT

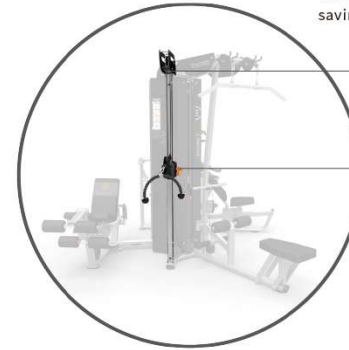

Quick installation, shares the stack with lat pull for saving space and cost.

31 vertical pulley positions for a large variety of different exercises.



Excellent structural design, easy & quick adjustment offers dynamic workout like chest press, incline press and shoulder press which meet various muscle groups training.



Adjustable handle is conveniently located for easy access.

Excellent structural design, easy & quick adjustment seat is for prone leg curls or leg extension exercises which satisfy various muscle groups.

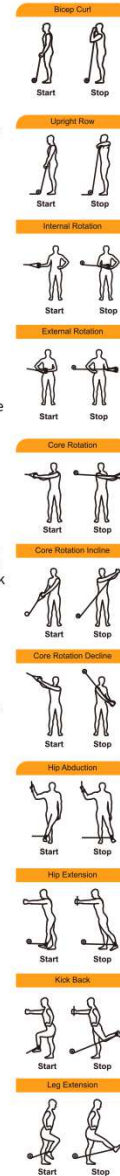

## ES9030 DUAL ADJUSTABLE PULLEY ES7011 BENCH



Chin-up/pull-up bar with ergonomic bends for regular grip, wide grip and reverse grip exercises.

31 vertical pulley positions for a large variety of different exercises.

With accessories as lat strap, long bar retractable strap, leg ext/curl strap and tricep rope, DAP offers users dynamic and various workouts.

Multi-position bench offers 5 upright/incline positions for back pad and 3 position for seat, which satisfies various workout experience.

The over-sized feet would stabilize the users during certain workouts like tricep extension.

Conveniently located iPad holder allows user to watch online training videos during the workouts, over-sized bottle holder is within reach.



Fold away bench for easy storage and space saving



ES9030(Long Shroud)

Product Dimension (L×W×H)	1734x1123x2150(mm) 68.3x44.2x84.7(in)
Product Weight	149.5kg/328.9lbs
Stacks Weight	77kgx2 (170lbsx2)



ES9030(Short Shroud)

Product Dimension (L×W×H)	1734x1123x2150(mm) 68.3x44.2x84.7(in)
Product Weight	121.5kg/267.3lbs
Stacks Weight	77kgx2 (170lbsx2)



ES7011

Product Dimension (L×W×H)	1440x525x490(mm) 56.7x20.7x19.3(in)
Product Weight	34.3kg/75.6lbs

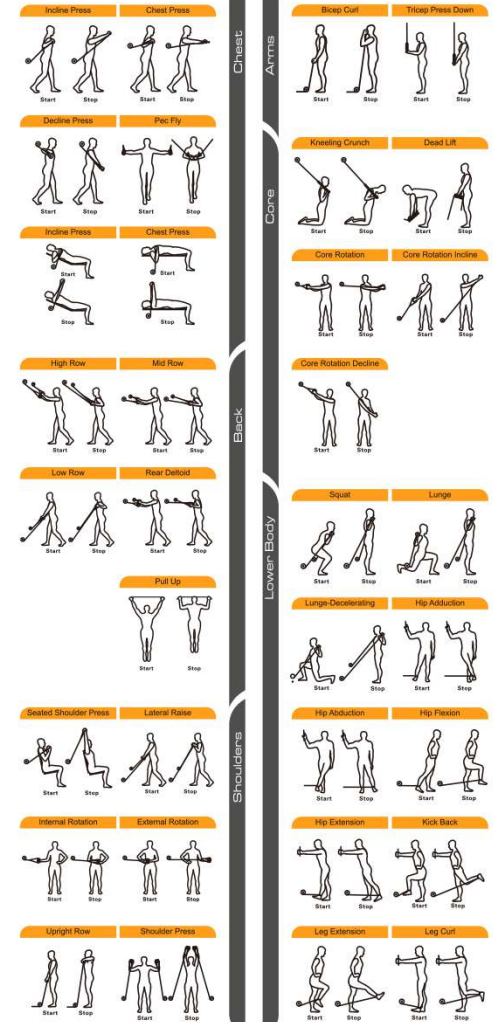

## ES7030 DUAL ADJUSTABLE PULLEY



Chin-up/pull-up bar with ergonomic bends for regular grip, wide grip and reverse grip exercises.

31 vertical pulley positions for a large variety of different exercises.

With accessories as lat strap, long bar retractable strap, leg ext/curl strap and triceps rope, DAP offers users dynamic and various workouts.  
\*Accessories sold separately.



TENSION ROPE

Product Dimension	650(mm)/25.6(in)
Pull	≥450kg/992.1lbs



HANDLE

Product Dimension	1126x35(mm) 44.3x1.4(in)
-------------------	-----------------------------



ES7030

Product Dimension (L×W×H)	1641x916x2142(mm) 64.6x36.1x84.3(in)
Stacks Weight	77kgx2 (170lbsx2)

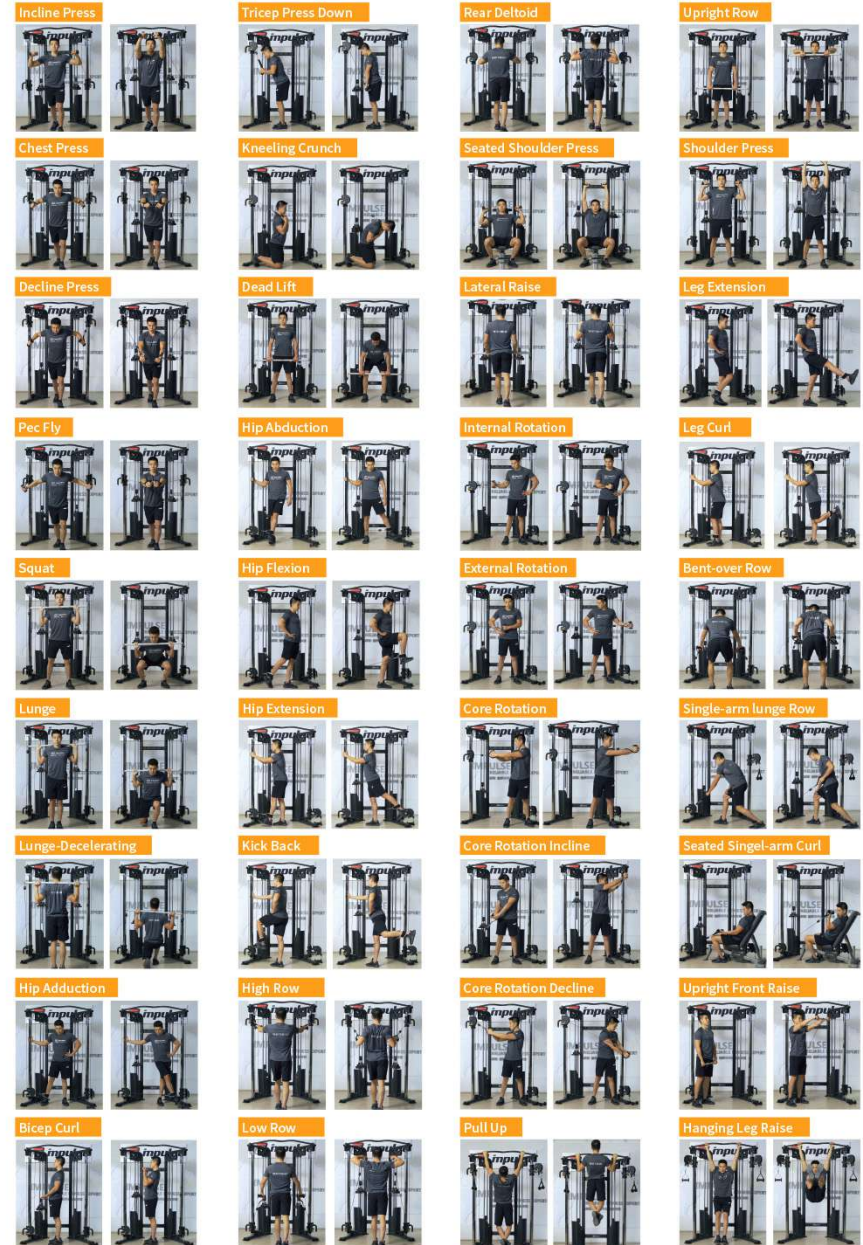

## ES2100 Multi-Functional Trainer with Smith



Product Dimension (L×W×H)	1681x1720x2090(mm) 66.18x67.72x82.28(in)
Product Weight	186.1kg/410.3lbs
Opt Weight Stack	170lbs/200lbs x 2 sets

## ES2000 Multi-Functional Trainer with Smith (Plate Loaded)



Product Dimension (L×W×H)	2007x1724x2126(mm) 79.01x67.87x83.70(in)
Product Weight	184kg/405.7lbs

### ES2000/2100 Accessory

Standard	POM Handle	Short Pole	Support Strap	Dip Arm
	Barbell Bar Storage	Ankle Strap	Double-ended Rope	Rowing Foot Pedal
Optional	ES2000OPT1 Pivot	ES2000OPT2 Foam Roller + Hi Pull-down Aluminum Rod		PTSHILO15000 Chop Bar



**IFHC  
HALF CAGE**

PRODUCT DIMENSION (L×W×H)	1681×1720×2090 (mm) 66.2×67.7×82.3 (in)
PRODUCT WEIGHT	100 kg / 221 lbs
40'	150 Sets



**IFHCP  
HALF CAGE PEC FLY ATTACHMENT**

PRODUCT DIMENSION (L×W×H)	953×356×1538 (mm) 37.5×14×60.6 (in)
PRODUCT WEIGHT	24.3 kg / 54 lbs
40'	508 Sets



**IFHCL  
HALF CAGE LAT ATTACHMENT**

PRODUCT DIMENSION (L×W×H)	1800×400×2100 (mm) 70.9×15.7×82.7 (in)
PRODUCT WEIGHT	41 kg / 90 lbs
40'	234 Sets



**IFHCS  
HALF CAGE SMITH ATTACHMENT**

PRODUCT DIMENSION (L×W×H)	1946×300×1727 (mm) 76.6×11.8×68 (in)
PRODUCT WEIGHT	33 kg / 73 lbs
40'	425 Sets
MAX. WEIGHT CAPACITY	200 kg / 440 lbs

**IFLATM  
LAT MACHINE**

PRODUCT DIMENSION (L×W×H)	1452×1224×2129 (mm) 57.2×48.2×83.8 (in)
PRODUCT WEIGHT	55.5 kg / 122 lbs
40'	302 Sets



**IFPC  
POWER CAGE**

PRODUCT DIMENSION (L×W×H)	1576×1256×2149 (mm) 62.0×49.4×84.6 (in)
PRODUCT WEIGHT	114 kg / 251 lbs
40'	90 Sets



**IFPCL  
POWER CAGE LAT ATTACHMENT**

PRODUCT DIMENSION (L×W×H)	1212×945×2053 (mm) 47.7×37.2×80.8 (in)
PRODUCT WEIGHT	31.8 kg / 70 lbs
40'	420 Sets





**IF45 45-DEGREE  
HYPEREXTENSION**

PRODUCT DIMENSION (L×W×H)	1224×743×739 (mm) 48.2×29.3×29.1 (in)
PRODUCT WEIGHT	23.5 kg / 52 lbs
40'	340 Sets



**IFAH ADJUSTABLE  
HYPEREXTENSION BENCH**

PRODUCT DIMENSION (L×W×H)	1260×743×917 (mm) 49.6×29.3×36.1 (in)
PRODUCT WEIGHT	36 kg / 79 lbs
40'	360 Sets



**IFRC  
ROMAN CHAIR**

PRODUCT DIMENSION (L×W×H)	1361×743×1091 (mm) 53.6×29.3×43 (in)
PRODUCT WEIGHT	30.5 kg / 67 lbs
40'	504 Sets



**IFFB  
FLAT BENCH**

PRODUCT DIMENSION (L×W×H)	1303×526×490 (mm) 51.3×20.7×19.3 (in)
PRODUCT WEIGHT	19.5 kg / 43 lbs
40'	532 Sets



**IFUB  
UTILITY BENCH**

PRODUCT DIMENSION (L×W×H)	862×596×874 (mm) 33.9×23.5×34.4 (in)
PRODUCT WEIGHT	12.7 kg / 28 lbs
40'	375 Sets



**IFFI  
FLAT/INCLINE BENCH**

PRODUCT DIMENSION (L×W×H)	1603×654×498 (mm) 63.1×25.7×19.6 (in)
PRODUCT WEIGHT	30 kg / 66 lbs
40'	396 Sets



**IFSPC SEATED  
PREACHER CURL**

PRODUCT DIMENSION (L×W×H)	1021×712×870 (mm) 40.2×28×34.3 (in)
PRODUCT WEIGHT	24.7 kg / 54 lbs
40'	420 Sets



**IFAAB ADJUSTABLE  
ABDOMINAL BENCH**

PRODUCT DIMENSION (L×W×H)	1624×570×1115 (mm) 63.9×22.4×43.9 (in)
PRODUCT WEIGHT	24 kg / 53 lbs
40'	450 Sets



**IFAC  
ABDOMINAL CRUNCH**

PRODUCT DIMENSION (L×W×H)	1103×476×578 (mm) 43.4×18.7×22.8 (in)
PRODUCT WEIGHT	17 kg / 37 lbs
40'	697 Sets



**IFOB  
OLYMPIC BENCH PRESS**

PRODUCT DIMENSION (L×W×H)	1439×1264×1086 (mm) 56.7×49.8×42.8 (in)
PRODUCT WEIGHT	62.5 kg / 138 lbs
40'	252 Sets



**IFARMA  
ARM CURL ATTACHMENT**

PRODUCT DIMENSION (L×W×H)	584×434×761 (mm) 23×17.1×30 (in)
PRODUCT WEIGHT	6.6 kg / 15 lbs
40'	840 Sets



**IFLEGA  
LEG EXTENSION/CURL ATTACHMENT**

PRODUCT DIMENSION (L×W×H)	539×426×470 (mm) 21.2×16.8×18.5 (in)
PRODUCT WEIGHT	7.3 kg / 16 lbs
40'	1728 Sets

STRENGTH

IF



**IFSTF  
STRETCH**

PRODUCT DIMENSION (L×W×H)	1865×1730×2150 (mm) 73.4×68.1×84.6 (in)
PRODUCT WEIGHT	90 kg / 198 lbs
40'	112 Sets



**IFPT  
POWER TOWER**

PRODUCT DIMENSION (L×W×H)	1242×1316×2113 (mm) 48.9×51.8×83.2 (in)
PRODUCT WEIGHT	76.5 kg / 169 lbs
40'	245 Sets



**IFSS  
SQUAT STAND**

PRODUCT DIMENSION (L×W×H)	1226×1575×1735 (mm) 48.3×62×68.3 (in)
PRODUCT WEIGHT	56.5 kg / 125 lbs
40'	320 Sets



**IFOFB  
FLAT BENCH PRESS**

PRODUCT DIMENSION (L×W×H)	1525×1310×1265 (mm) 60×51.6×49.8 (in)
PRODUCT WEIGHT	60.5 kg / 133 lbs
40'	154 Sets



**IFOIB  
INCLINE BENCH PRESS**

PRODUCT DIMENSION (L×W×H)	1560×1310×1395 (mm) 61.4×51.6×54.9 (in)
PRODUCT WEIGHT	68.5 kg / 151 lbs
40'	147 Sets

STRENGTH

IF



**IFLPHS  
LEG PRESS/HACK SQUAT MACHINE**

PRODUCT DIMENSION (L×W×H)	2245×818×1298 (mm) 88.4×32.2×51.1 (in)
PRODUCT WEIGHT	162.5 kg / 358 lbs
40'	108 Sets
MAX. WEIGHT CAPACITY	200 kg / 440 lbs



**IFFID  
MULTI-PURPOSE BENCH**

PRODUCT DIMENSION (L×W×H)	1582×655×501 (mm) 62.3×25.8×19.7 (in)
PRODUCT WEIGHT	33 kg / 73 lbs
40'	417 Sets



**IFODB  
DECLINE BENCH PRESS**

PRODUCT DIMENSION (L×W×H)	1900×1310×1156 (mm) 74.8×51.6×45.5 (in)
PRODUCT WEIGHT	70 kg / 154 lbs
40'	154 Sets







**IFABM**  
AB/BACK MACHINE

PRODUCT DIMENSION (L×W×H)	1539×1041×1060 (mm) 60.6×41.0×41.7 (in)
PRODUCT WEIGHT	38.5 kg / 85 lbs
40'	119 Sets



**IFCR**  
CALF RAISE

PRODUCT DIMENSION (L×W×H)	1207×559×1016 (mm) 43.3×22.0×40.0 (in)
PRODUCT WEIGHT	47.5 kg / 78 lbs
40'	520 Sets
MAX. WEIGHT CAPACITY	100 kg / 220 lbs



**IFBR**  
BARBELL RACK

PRODUCT DIMENSION (L×W×H)	792×844×1380 (mm) 31.2×33.2×54.3 (in)
PRODUCT WEIGHT	43.7 kg / 96 lbs
40'	195 Sets



**IFPTO**  
PLATE TREE-OLYMPIC

PRODUCT DIMENSION (L×W×H)	843×632×1108 (mm) 33.2×24.9×43.6 (in)
PRODUCT WEIGHT	19.5 kg / 43 lbs
40'	890 Sets

**IFLEGM**  
LEG EXTENSION/CURL MACHINE

PRODUCT DIMENSION (L×W×H)	1055×1044×1053 (mm) 41.5×41.1×41.5 (in)
PRODUCT WEIGHT	51 kg / 112 lbs
40'	192 Sets



**IFDB3**  
DUMBBELL RACK-3'

PRODUCT DIMENSION (L×W×H)	1079×473×677 (mm) 42.5×18.6×26.7 (in)
PRODUCT WEIGHT	29 kg / 64 lbs
40'	600 Sets



**IFDB4**  
DUMBBELL RACK-4'

PRODUCT DIMENSION (L×W×H)	1372×475×869 (mm) 54×18.7×34.2 (in)
PRODUCT WEIGHT	35.3 kg / 78 lbs
40'	430 Sets



**IFDB4A**  
DUMBBELL RACK-4' ATTACHMENT

PRODUCT DIMENSION (L×W×H)	1242×244×74 (mm) 48.9×9.6×2.9 (in)
PRODUCT WEIGHT	12 kg / 26 lbs
40'	1400 Sets

## IF2060 2060 HOME GYM

PRODUCT DIMENSION (L×W×H)	3143×1705×2100 (mm) 123.7×67.1×82.7 (in)
PRODUCT WEIGHT	442.8 kg / 976 lbs
40'	40 Sets
WEIGHT STACK	2×91 kg / 200 lbs



## IF1560 1560 HOME GYM

PRODUCT DIMENSION (L×W×H)	1905×1240×2121 (mm) 75×48.8×83.5 (in)
PRODUCT WEIGHT	223 kg / 492 lbs
40'	68 Sets
WEIGHT STACK	91 kg / 200 lbs



## IFLP3 HOME GYM ATTACHMENT

PRODUCT DIMENSION (L×W×H)	1673×1040×971 (mm) 65.9×40.9×38.2 (in)
PRODUCT WEIGHT	65 kg / 143 lbs
40'	220 Sets



## IF1860 1860 HOME GYM

PRODUCT DIMENSION (L×W×H)	1897×1075×2118 (mm) 74.7×42.3×83.4 (in)
PRODUCT WEIGHT	253.7 kg / 559 lbs
40'	60 Sets
WEIGHT STACK	91 kg / 200 lbs



IF1860+IFLP3



IF2060+IFLP3





### IFFT FUNCTIONAL TRAINER

PRODUCT DIMENSION (L×W×H)	1662×1102×2122 (mm) 65.4×43.4×83.5 (in)
PRODUCT WEIGHT	336 kg / 741 lbs
40'	56 Sets
WEIGHT STACK	2×91 kg / 200 lbs

### IFFTOPT MULTI-SELECT STABILIZER

PRODUCT DIMENSION (L×W×H)	1075×260×1120 (mm) 42.3×10.2×44 (in)
PRODUCT WEIGHT	17.3 kg / 38 lbs IFFT+IFFTOPT



### HG5 CABLE MOTION GYM

PRODUCT DIMENSION (L×W×H)	1451×1339×2132 (mm) 57.1×52.7×83.9 (in)
PRODUCT WEIGHT	195.9 kg / 431.9 lbs
40'	82 Sets
WEIGHT STACK	73 kg / 160 lbs

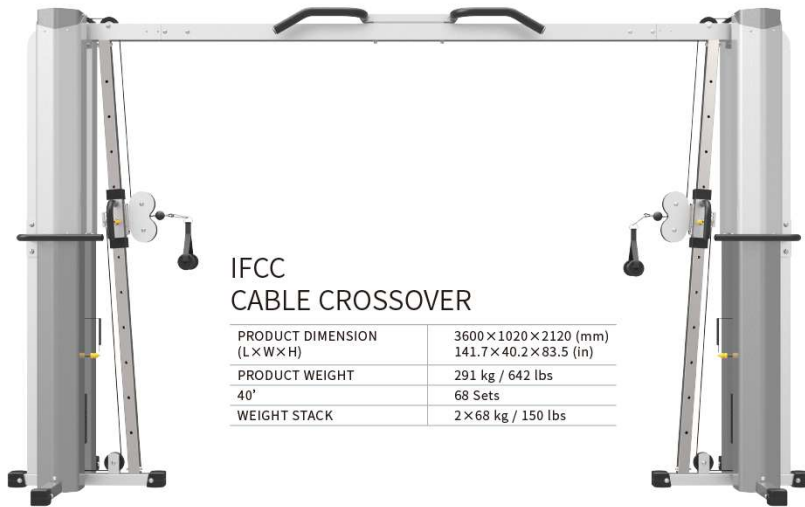

### IFCC CABLE CROSSOVER

PRODUCT DIMENSION (L×W×H)	3600×1020×2120 (mm) 141.7×40.2×83.5 (in)
PRODUCT WEIGHT	291 kg / 642 lbs
40'	68 Sets
WEIGHT STACK	2×68 kg / 150 lbs



### IFFI5 BENCH

PRODUCT DIMENSION (L×W×H)	1380×490×441 (mm) 54.3×19.3×17.3 (in)
PRODUCT WEIGHT	25.7 kgs / 56.7 lbs
MAX WEIGHT CAPACITY	200kg / 441 lbs

# RE-LIFE

Hydraulic Strength Training Equipment



## RL Line >>>

In the face of such a busy pace of life, Impulse timely put forward the concept of 'light fitness', and explored how to exercise to 'win more with less effort', integrate exercise into your daily life and make it a wonderful enjoyment. Unlike conventional strength equipment, 'light fitness tends to listen to the voice of the heart.

Impulse RE-LIFE light fitness series is tailored for the urban white-collars and young women who love sports, as well as small studios and community gyms. Impulse named the series after RE-LIFE implying that customers can regain the vitality of the body and rebuild the quality of life by using this series of products.

The RE-LIFE series complements any traditional fitness scenario, suitable for users from almost all ages and fitness levels.

### 8+X Flexible combinations, more possibilities

RE-LIFE series consists of 8 sets of hydraulic resistance training equipment which can be used for bidirectional constant speed operation and 1 set of stretching machine. 8 sets of hydraulic resistance training equipment can realize the function of 15 kinds of traditional strength equipment, and the stretching machine is helpful before and after exercise. Alternatively, depending on the user's needs, the stretching machine can be replaced with a BOSU ball for balance training, cardio pedals, or a HIIT SKI&ROW\* or ULTRA BIKE\*. Users of different ages and physical qualities can find their own training methods through the flexible combination of 8+X.

\* SKI&ROW and ULTRA BIKE are products of Impulse.



Ultimate User Experience Design Driven Products Environment Friendly



The dual-position handle design ensures that the user always finds the perfect posture.



The selection of upholstery is soft, comfortable and elastic, making it more skin-friendly during training and reducing wear. The multifunctional holder allows you to take water cup or mobile phone at your fingertips.



Adjustable hydraulic resistance makes adjustment more refined with eye-catching knob design.

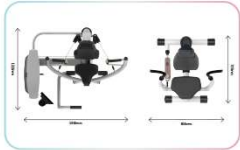

Concise modeling design can save half of the storage and transportation space compared with conventional equipment, the built-in transport wheel design makes it easier to move.



The resistance adapts itself and can stop the movement at any time to reduce the injury risk. In addition, the integrated stable adjusting device can easily adjust the horizontal stability of the product.



Optional painting and upholstery color. (Terms and conditions applied)

STRENGTH

RL

STRENGTH

RL



RL8101 CHEST PRESS/ROW

PRODUCT DIMENSION (L×W×H)	818×737×1260 (mm) 32.2×29.0×49.6 (in)
PRODUCT WEIGHT	40.4kg/89.1lbs



RL8102 OVERHEAD PRESS/PULLDOWN

PRODUCT DIMENSION (L×W×H)	1120×1000×1296 (mm) 44.1×39.4×50.0 (in)
PRODUCT WEIGHT	45.5kg/100.3lbs



RL8103 BICEPS CURL TRICEPS EXTENSION

PRODUCT DIMENSION (L×W×H)	1178×736×859 (mm) 46.4×19.0×33.8 (in)
PRODUCT WEIGHT	32.2kg/71lbs



RL8104 PEC FLY/REAR DELTOID

PRODUCT DIMENSION (L×W×H)	1139×895×1286 (mm) 44.8×35.2×50.6 (in)
PRODUCT WEIGHT	48.6kg/107.1lbs



RL8105 LEG EXTENSION/LEG CURL

PRODUCT DIMENSION (L×W×H)	1174×830×1260 (mm) 46.2×32.7×49.6 (in)
PRODUCT WEIGHT	51.8kg/114.2lbs



RL8107 Ab CRUNCH/BACK EXTENSION

PRODUCT DIMENSION (L×W×H)	1097×842×1165 (mm) 43.2×33.1×45.9 (in)
PRODUCT WEIGHT	44.2kg/97.4lbs



RL8108 HIP ABDUCTION/ADDUCTION

PRODUCT DIMENSION (L×W×H)	1122×737×1260 (mm) 44.2×29.0×49.6 (in)
PRODUCT WEIGHT	51.6kg/113.8lbs



RL8110 LEG PRESS

PRODUCT DIMENSION (L×W×H)	1737×737×1260 (mm) 68.4×29.0×49.6 (in)
PRODUCT WEIGHT	71kg/156.5lbs



RL8106 STRETCH

PRODUCT DIMENSION (L×W×H)	1377×755×1237 (mm) 54.2×29.7×48.7 (in)
PRODUCT WEIGHT	37kg/81.6lbs