

www.impulse-fitness.kz



im impulse

Your Wellness Solution Provider

ECP Line >>>

Impulse Fitness proudly presents the EVOLUTION CURVE Series, a groundbreaking line of plate-loaded strength machines. Incorporating a linkage-adjustable force structure in most models, these machines are tailored to match the strength curve characteristics of specific muscle groups, ensuring user comfort, training efficiency, and safety throughout the workout. Named the EVOLUTION CURVE PLATE-LOADED STRENGTH SERIES, or simply the ECP series, it promises an exceptional training experience.

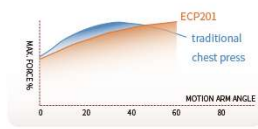

Force Curve Comparison Chart

Compared to traditional plate-loaded equipment, the ECP series offers smoother force lines from the initial lift, ensuring that there is no loss of force toward the end of the movement.



ECP101 SHOULDER PRESS

PRODUCT DIMENSION (L×W×H)	1638×1515×1455 (mm) 64.5×59.6×57.3 (in)
PRODUCT WEIGHT	215 kg/474.0 lbs
MAX. WEIGHT CAPACITY	200 kg/440.9 lbs



ECP201 CHEST PRESS

PRODUCT DIMENSION (L×W×H)	1800×1750×1800 (mm) 70.9×68.9×70.9 (in)
PRODUCT WEIGHT	265 kg/584.2 lbs
MAX. WEIGHT CAPACITY	200 kg/440.9 lbs





Spacious handrail-style assist handles provide better support for users.



Split-function design caters to unilateral and bilateral training needs.



The leg foam can be adjusted in 7 levels.

ECP301 PULLDOWN

PRODUCT DIMENSION (L×W×H)	1745×1645×1932 (mm) 68.7×64.8×76.1 (in)
PRODUCT WEIGHT	210 kg/463.0 lbs
MAX. WEIGHT CAPACITY	200 kg/440.9 lbs



Dual-purpose design with both shoulder and waist carrying options.



Adjustable foot pedal angle with 4 levels from 35° to 50°.



Adjustable safety limit to effectively protect users.

ECP617 HACK SQUAT

PRODUCT DIMENSION (L×W×H)	2185×1290×1416 (mm) 86.0×50.8×55.7 (in)
PRODUCT WEIGHT	315 kg/694.5 lbs
MAX. WEIGHT CAPACITY	400 kg/881.8 lbs



Spacious handrail-style assist handles provide better support.



Dual-handle design with both overhand and underhand grips.



Adjustable chest pad angle with 4 levels.



Low-entry design for easy access on and off the machine.

ECP302 SEATED ROW

PRODUCT DIMENSION (L×W×H)	1600×1800×1100 (mm) 63.0×70.9×43.3 (in)
PRODUCT WEIGHT	190 kg/418.9 lbs
MAX. WEIGHT CAPACITY	120 kg/264.6 lbs



Convenient dual-sided handle adjustments.



Balance weight added.

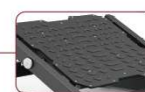

Adjustable foot pedal angle with six settings and a spacious platform (750*665).

ECP713 SQUAT

PRODUCT DIMENSION (L×W×H)	2300×1260×1790 (mm) 90.6×49.6×70.5 (in)
PRODUCT WEIGHT	330 kg/727.5 lbs
MAX. WEIGHT CAPACITY	400 kg/881.8 lbs



SL Line >>>

Easy to use, neat appearance, the SL line is a high quality commercial plate loaded series. The user-friendly design makes working out more simple, efficient, comfortable and satisfying.

Tubing: thickness range from 2.5 mm to 3mm, 50mmx100mm tubing, electro-welded to maximum integrity.

Color: black and red (Other colors are optional based on customer requirements)

Finish: Electrostatic powder-coated and heat cured after adhesiveness enhancement pre-treatment for superior durability



Compact - space efficient design requires minimal floor space.

Pad total thickness is 70mm.

Easy-to-use, flexible adjustments allow for optimal exercise positions.



* COLOR OPTIONAL



SL7001 CHEST PRESS

PRODUCT DIMENSION (L×W×H)	1937×1370×1717 (mm) 76.3×53.9×67.6 (in)
PRODUCT WEIGHT	170.5 kg / 375.9 lbs
40'	70 Sets
MAX. WEIGHT CAPACITY	300 Kg / 660 lbs



SL7002 PULLDOWN

PRODUCT DIMENSION (L×W×H)	1482×1489×1967 (mm) 58.3×58.6×77.4 (in)
PRODUCT WEIGHT	169 kg / 372.6 lbs
40'	81 Sets
MAX. WEIGHT CAPACITY	300 kg / 660 lbs



SL7005 INCLINE CHEST PRESS

PRODUCT DIMENSION (L×W×H)	1900×1523×1779 (mm) 74.8×60×70 (in)
PRODUCT WEIGHT	184 kg / 405.7 lbs
40'	72 Sets
MAX. WEIGHT CAPACITY	300 kg / 660 lbs



SL7006 LEG PRESS

PRODUCT DIMENSION (L×W×H)	2226×1421×1415 (mm) 87.6×55.9×55.7 (in)
PRODUCT WEIGHT	195 kg / 429.9 lbs
40'	65 Sets
MAX. WEIGHT CAPACITY	400 kg / 880 lbs



SL7003 SHOULDER PRESS

PRODUCT DIMENSION (L×W×H)	1558×1818×1487 (mm) 61.3×71.6×58.5 (in)
PRODUCT WEIGHT	171.5 kg / 378.1 lbs
40'	89 Sets
MAX. WEIGHT CAPACITY	300 kg / 660 lbs



SL7004 LOW ROW

PRODUCT DIMENSION (L×W×H)	1761×1458×1650 (mm) 69.3×57.4×65 (in)
PRODUCT WEIGHT	170 kg / 374.8 lbs
40'	69 Sets
MAX. WEIGHT CAPACITY	300 kg / 660 lbs



SL7007 ROW

PRODUCT DIMENSION (L×W×H)	1815×1500×1334 (mm) 71.5×59.1×52.5 (in)
PRODUCT WEIGHT	160 kg / 352.7 lbs
40'	87 Sets
MAX. WEIGHT CAPACITY	300 kg / 660 lbs



SL7008 REAR KICK

PRODUCT DIMENSION (L×W×H)	1680×1229×1636 (mm) 66.1×48.4×64.4 (in)
PRODUCT WEIGHT	144 kg / 317.5 lbs
40'	82 Sets
MAX. WEIGHT CAPACITY	150kg / 330lbs



SL7013 GLUTE HAM BENCH

PRODUCT DIMENSION (L×W×H)	1562×914×1477 (mm) 61.5×36×58.1 (in)
PRODUCT WEIGHT	70 kg / 154 lbs
40'	105 Sets



SL7017 SEATED CALF RAISE

PRODUCT DIMENSION (L×W×H)	1475×765×845 (mm) 58×30.1×33.3 (in)
PRODUCT WEIGHT	56 kg / 123 lbs
40'	174 Sets
MAX. WEIGHT CAPACITY	150 kg / 330 lbs



SL7021 HACK SQUAT

PRODUCT DIMENSION (L×W×H)	2205×1880×1285 (mm) 86.8×74×50.6 (in)
PRODUCT WEIGHT	235.5 kg / 519.2 lbs
MAX. WEIGHT CAPACITY	400 kg / 880 lbs



SL7019 INCLINE ROW

PRODUCT DIMENSION (L×W×H)	1960×1020×1253 (mm) 77.2×40.2×49.3 (in)
PRODUCT WEIGHT	89 kg / 196 lbs
40'	97 Sets
MAX. WEIGHT CAPACITY	150 kg / 330 lbs



SL7020 45 LEG PRESS

PRODUCT DIMENSION (L×W×H)	2499×1879×1544 (mm) 98.4×74×60.8 (in)
PRODUCT WEIGHT	249kg / 548lbs
40'	58 Sets
MAX. WEIGHT CAPACITY	450kg / 990lbs





SL7023 BICEP CURL

PRODUCT DIMENSION (L×W×H)	1492×1045×1204 (mm) 58.7×41.1×47.4 (in)
PRODUCT WEIGHT	114 kg / 251.3 lbs
40'	96 Sets
MAX. WEIGHT CAPACITY	120 kg / 264 lbs



SL7024 TRICEP DIP

PRODUCT DIMENSION (L×W×H)	1733×1580×1202 (mm) 68.2×62.2×47.3 (in)
PRODUCT WEIGHT	166.3 kg / 366.6 lbs
MAX. WEIGHT CAPACITY	300 kg / 660 lbs



SL7032 STANDING CALF RAISE

PRODUCT DIMENSION (L×W×H)	1615×1375×1730 (mm) 63.6×54.1×68.1 (in)
PRODUCT WEIGHT	146.2 kg/322.3 lbs
MAX. WEIGHT CAPACITY	300 kg/660 lbs



SL7034 SQUAT

PRODUCT DIMENSION (L×W×H)	2260×1260×1800 (mm) 88.9×49.6×70.9 (in)
PRODUCT WEIGHT	212 kg/467.4 lbs
MAX. WEIGHT CAPACITY	400 kg/880 lbs



SL7025 LEG EXTENSION

PRODUCT DIMENSION (L×W×H)	1270×1690×1005 (mm) 50×66.5×39.6 (in)
PRODUCT WEIGHT	130.9 kg / 288.6 lbs
MAX. WEIGHT CAPACITY	300 kg / 660 lbs



SL7026 LEG CURL

PRODUCT DIMENSION (L×W×H)	1430×1045×1200 (mm) 56.3×41.1×47.2 (in)
PRODUCT WEIGHT	141.1 kg / 311.1 lbs
MAX. WEIGHT CAPACITY	120 kg / 264 lbs



SL7036 ABDOMINAL

PRODUCT DIMENSION (L×W×H)	1623×1267×1642 (mm) 63.9×49.9×64.6 (in)
PRODUCT WEIGHT	132 kg/291 lbs
MAX. WEIGHT CAPACITY	120 kg/264 lbs





SL7038 TOTAL HIP

PRODUCT DIMENSION (L×W×H)	1620×1610×1110 (mm) 63.8×63.4×43.7 (in)
PRODUCT WEIGHT	114.7 kg/253 lbs
MAX. WEIGHT CAPACITY	150 kg/331 lbs



SL7039 STANDING PRESS

PRODUCT DIMENSION (L×W×H)	2170×2000×2135 (mm) 85.4×78.7×84.1 (in)
PRODUCT WEIGHT	181.4 kg/399.9 lbs
MAX. WEIGHT CAPACITY	300 kg/661 lbs



SL7028 FLAT BENCH PRESS

PRODUCT DIMENSION (L×W×H)	1910x1738x1315 (mm) 75.2x68.4x51.8 (in)
PRODUCT WEIGHT	111 kg/244.7 lbs
MAX. WEIGHT CAPACITY	300 kg/660 lbs



SL7029 INCLINE BENCH PRESS

PRODUCT DIMENSION (L×W×H)	2059x1738x1496 (mm) 81.1x68.4x58.9 (in)
PRODUCT WEIGHT	109 kg/240.3 lbs
MAX. WEIGHT CAPACITY	300 kg/660 lbs



SL7040 SQUAT LUNGE

PRODUCT DIMENSION (L×W×H)	1700×1670×640 (mm) 66.9×65.7×25.2 (in)
PRODUCT WEIGHT	123 kg/271 lbs
MAX. WEIGHT CAPACITY	300 kg/661 lbs



SL7030 DECLINE BENCH PRESS

PRODUCT DIMENSION (L×W×H)	2188x1738x1315 (mm) 86.1x68.4x51.8 (in)
PRODUCT WEIGHT	110.3 kg/243.2 lbs
MAX. WEIGHT CAPACITY	300 kg/660 lbs



SL7031 SHOULDER BENCH PRESS

PRODUCT DIMENSION (L×W×H)	1719x1261x1920(mm) 67.7x49.6x75.6(in)
PRODUCT WEIGHT	146.5 kg/323.0 lbs
MAX. WEIGHT CAPACITY	400 kg/880 lbs



SL7009 POWER RACK

PRODUCT DIMENSION (L×W×H)	2031×1499×2278 (mm) 80×59×89.7 (in)
PRODUCT WEIGHT	200 kg / 441 lbs
40'	82 Sets

SL7009OPT
WEIGHT PLATE RACK OPTION

PRODUCT DIMENSION (L×W×H)	1674×717×2199 (mm) 65.9×28.2×86.6 (in)
PRODUCT WEIGHT	63.5 kg / 140 lbs
40'	144 Sets



SL7010 PLATE RACK

PRODUCT DIMENSION (L×W×H)	891×628×1228 (mm) 35.1×24.7×48.3 (in)
PRODUCT WEIGHT	44 kg / 97 lbs
40'	242 Sets



SL7027 BARBELL RACK

PRODUCT DIMENSION (L×W×H)	950×910×1612 (mm) 37.4×35.8×63.5 (in)
PRODUCT WEIGHT	73 kg / 161 lbs
40'	112 Sets



SL7014 HALF POWER RACK

PRODUCT DIMENSION (L×W×H)	1390×1747×2442 (mm) 54.7×68.8×96.1 (in)
PRODUCT WEIGHT	153 kg / 337 lbs
40'	108 Sets



SL7015 FULL POWER RACK

PRODUCT DIMENSION (L×W×H)	1966×1747×2442 (mm) 77.4×68.8×96.1 (in)
PRODUCT WEIGHT	216 kg / 476 lbs
40'	83 Sets

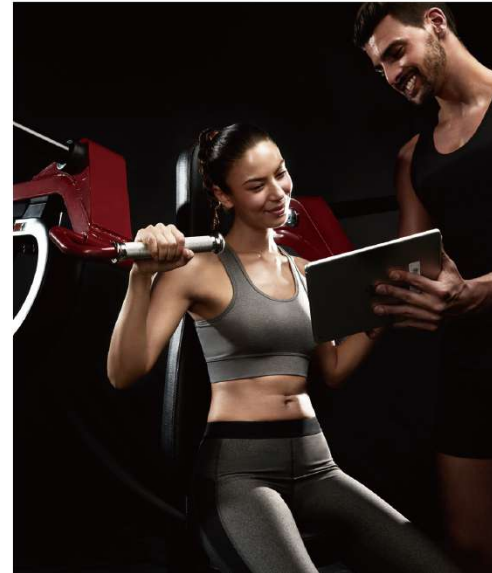

SL7016 DUMBBELL RACK

PRODUCT DIMENSION (L×W×H)	2260×760×740 (mm) 89.0×29.9×29.1 (in)
PRODUCT WEIGHT	75.9 kg/167.3 lbs
40'	240 Sets
MAX. WEIGHT CAPACITY	700 kg/ 1540 lbs



SL7011 FID BENCH

PRODUCT DIMENSION (L×W×H)	1350×670×1350 (mm) 53.1×26.4×53.1 (in)
PRODUCT WEIGHT	44 kg / 97 lbs
40'	252 Sets



SL7012 FID BENCH

PRODUCT DIMENSION (L×W×H)	1550×670×1350 (mm) 61×26.4×53.1 (in)
PRODUCT WEIGHT	47 kg / 104 lbs
40'	252 Sets



SL7041 SUPER OLYMPIC BENCH

PRODUCT DIMENSION (L×W×H)	2410×1743×1622 (mm) 94.9×68.6×63.9 (in)
PRODUCT WEIGHT	141.3 kg/312 lbs
MAX. WEIGHT CAPACITY	300 kg/661 lbs

SL7042
MAGIC RACK/SMITH MACHINE

PRODUCT DIMENSION (L×W×H)	2315×2241×2391 (mm) 91.1×88.2×94.1 (in)
PRODUCT WEIGHT	313.4 kg/690.9 lbs
MAX. WEIGHT CAPACITY	300 kg/661 lbs



SL7018 ARM CURL

PRODUCT DIMENSION (L×W×H)	1136x860x1016 (mm) 44.7x33.9x40.0(in)
PRODUCT WEIGHT	70 kg/154.3 lbs
MAX.WEIGHT CAPACITY	300 kg/661.4 lbs



SL7022 UTILITY BENCH

PRODUCT DIMENSION (L×W×H)	1191×630×822 (mm) 46.9×24.8×32.4 (in)
PRODUCT WEIGHT	27.8 kg / 61.3 lbs
40'	253 Sets



SL7035 FLAT BENCH

PRODUCT DIMENSION (L×W×H)	1281x630x425 (mm) 50.4x24.8x16.7 (in)
PRODUCT WEIGHT	25.3 kg/55.8 lbs
MAX. WEIGHT CAPACITY	300 kg/660 lbs



SL7043 MULTI AB BENCH

PRODUCT DIMENSION (L×W×H)	1722×630×912 (mm) 67.8×24.8×35.9 (in)
PRODUCT WEIGHT	54 kg /119 lbs
MAX. WEIGHT CAPACITY	150 kg/331 lbs



SL7044 STRETCH

PRODUCT DIMENSION (L×W×H)	1567×630×1263 (mm) 61.7×24.8×49.7 (in)
PRODUCT WEIGHT	50 kg/110 lbs
MAX. WEIGHT CAPACITY	150 kg/331 lbs



SL7045
VERTICAL KNEE RAISE/DIP STAND

PRODUCT DIMENSION (L×W×H)	1189×765×1537 (mm) 46.8×30.1×60.5 (in)
PRODUCT WEIGHT	74.3 kg/163.8 lbs
MAX. WEIGHT CAPACITY	150 kg/331 lbs



SL7045OPT
CHIN-UP ATTACHMENT

PRODUCT DIMENSION (L×W×H)	1189×1157×2388 (mm) 46.8×45.6×94.0 (in)
PRODUCT WEIGHT	31.5 kg/69 lbs
MAX. WEIGHT CAPACITY	150 kg/331 lbs



SL7051
ASSISTED NORDIC HAM

PRODUCT DIMENSION (L×W×H)	1648×1323×1684 (mm) 64.9×52.1×66.3 (in)
PRODUCT WEIGHT	101 kg/222.7 lbs
MAX. WEIGHT CAPACITY	100 kg/220.5 lbs



SL7055
BELT SQUAT

PRODUCT DIMENSION (L×W×H)	1972×1541×1137 (mm) 77.6×60.7×44.8 (in)
PRODUCT WEIGHT	146 kg/321.9 lbs
MAX. WEIGHT CAPACITY	300 kg/661 lbs



SL7046
ISO-LATERAL SUPER CHEST PRESS

PRODUCT DIMENSION (L×W×H)	2502×2179×1136 (mm) 98.5×85.8×44.7 (in)
PRODUCT WEIGHT	147.5 kg/325.2 lbs
MAX. WEIGHT CAPACITY	150 kg/331 lbs



SL7047
MULTI HYPER EXTENSION

PRODUCT DIMENSION (L×W×H)	1340×947×765 (mm) 52.8×37.3×30.1 (in)
PRODUCT WEIGHT	55.2 kg/122 lbs
MAX. WEIGHT CAPACITY	150 kg/331 lbs



SL7057
PENDULUM SQUAT

PRODUCT DIMENSION (L×W×H)	2252×1314×1675 (mm) 88.7×51.7×65.9 (in)
PRODUCT WEIGHT	250 kg/551.2 lbs
MAX. WEIGHT CAPACITY	200 kg/440.9 lbs

STRENGTH

SL



HSP7051
HIGH PRONE ROW BENCH

PRODUCT DIMENSION (L×W×H)	1790×1310×1180 (mm) 70.5×51.6×46.5 (in)
PRODUCT WEIGHT	80kg/176.4lbs



HSP7053 LEG CURL

PRODUCT DIMENSION (L×W×H)	1705×620×742 (mm) 67.1×24.4×29.2 (in)
PRODUCT WEIGHT	40kg/88.2lbs



HSP7052 HIGH ROW

PRODUCT DIMENSION (L×W×H)	1875×1713×2123 (mm) 73.8×67.4×83.6 (in)
PRODUCT WEIGHT	160kg/352.7lbs

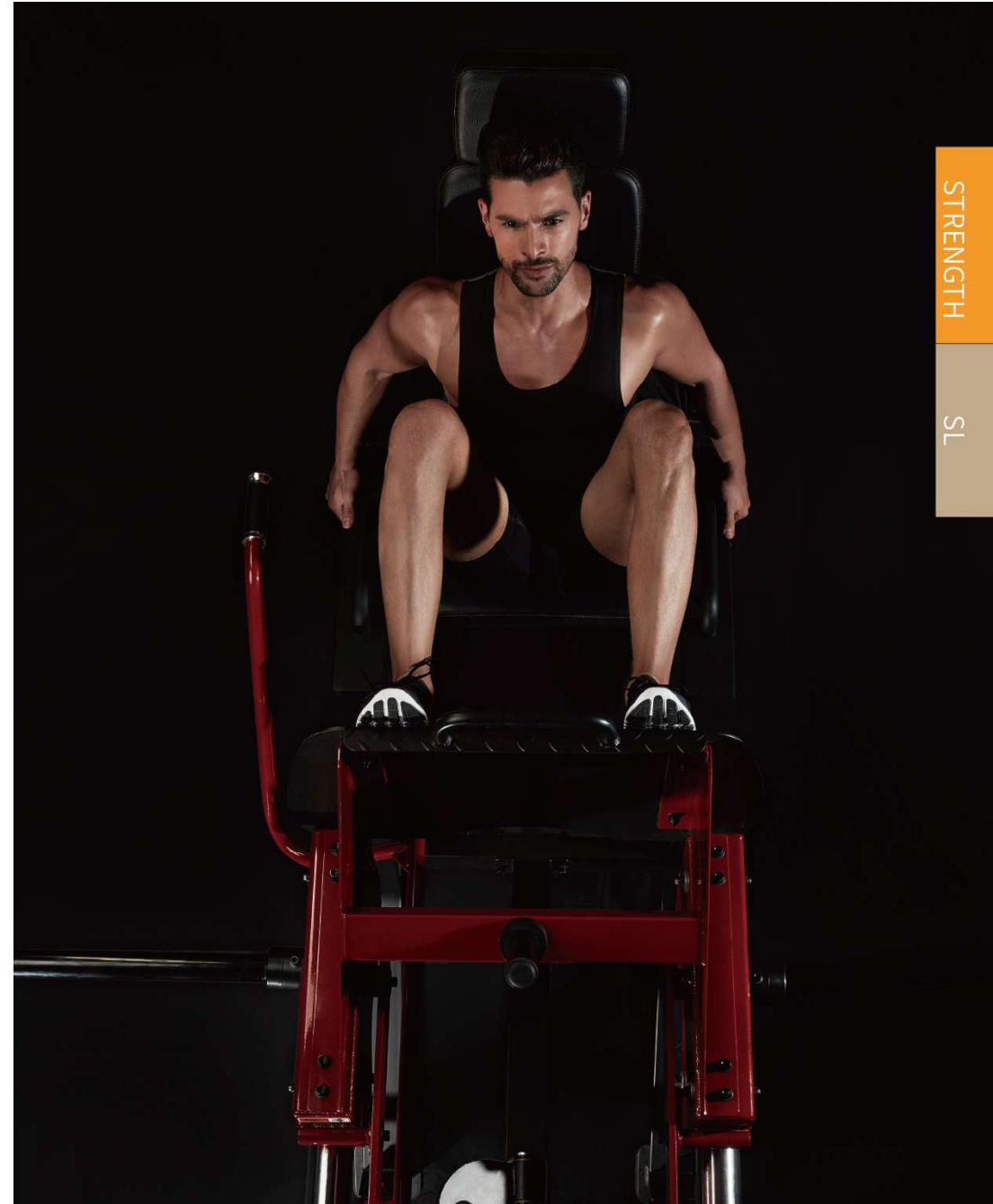

STRENGTH

SL

IFP Line >>>

- **Professional:** The 14 sets of products include equipment for exercising various muscle groups such as the chest, shoulder, back, legs, and arms. They are designed in strict accordance with parameters such as human mechanics and muscle force lines. This series of equipment is not limited to the training of conventional large muscle groups, but also takes into account the more specialized movement pattern training and more subdivided product design.
- **Functionality:** The 14 sets of products include several multi-functional products, which can meet the needs of multi-function, multi-muscle group and multi-action without affecting the use of a single function. It greatly solves the requirements of the site environment, two machines to one but not compromise on the function.
- **Simplicity:** On the basis of not sacrificing functionality, IFP series reduces the overall occupied area through structural design, so that more equipment can be arranged in the same area, which meets the needs of fitness practitioners for equipment diversity. And the overall structure is simple, reducing useless structures without affecting the maximum weight capacity, frequency of use, and intensity of use.

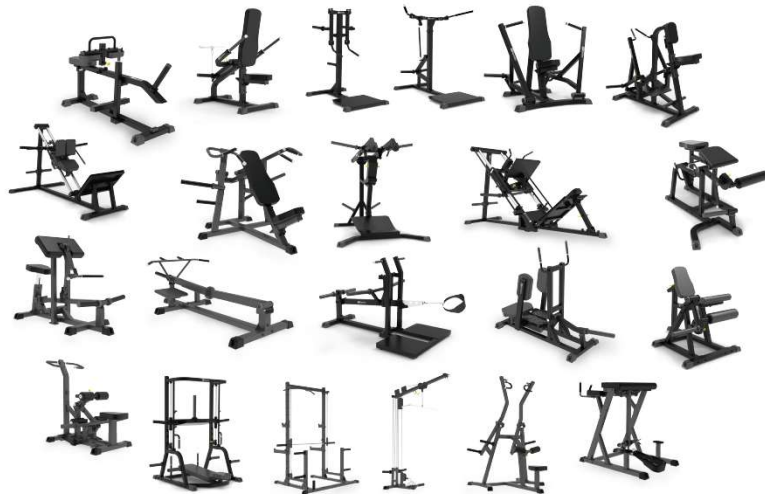

Dual-position handle design to meet the needs of trainees with different arm spans and different shoulder press distances.

Inclined backrest to significantly reduce pressure on the lower back while in a seated position.

Pivot point height matched to the user's shoulder height, providing a more comfortable user experience and precise muscle stimulation.

Limited-range mechanism for the moving arm to control its range of motion, preventing overextension and ensuring exercise safety.

IFP1101 SEATED SHOULDER PRESS

PRODUCT DIMENSION (L×W×H)	1579×1520×1069 (mm) 62.2×59.8×42.1 (in)
PRODUCT WEIGHT	87 kg/191.8 lbs
MAX. WEIGHT CAPACITY	300 kg/661.4 lbs



The height of the turning point matches the height of the user's shoulder, giving the user a more comfortable experience and precise stimulation of muscle groups.

Limit the use range of the lift-arm to avoid overextension.

The movable handle can meet the holding positions of users with different arm spans.

IFP1103 STANDING LATERAL RAISE

PRODUCT DIMENSION (L×W×H)	1165×885×1550 (mm) 45.9×34.8×61.0 (in)
PRODUCT WEIGHT	57.3 kg/126.3 lbs
MAX. WEIGHT CAPACITY	200 kg/440.9 lbs



IFP1201 SEATED CHEST PRESS

PRODUCT DIMENSION (L×W×H)	1276×984×1248 (mm) 50.2×38.7×49.1 (in)
PRODUCT WEIGHT	64.2 kg/141.5lbs
MAX. WEIGHT CAPACITY	200 kg/440.9 lbs



IFP1206 STANDING CHEST FLY

PRODUCT DIMENSION (L×W×H)	1515×1310×1491 (mm) 59.6×51.6×58.7 (in)
PRODUCT WEIGHT	70 kg/154.3 lbs
MAX. WEIGHT CAPACITY	200 kg/440.9 lbs



IFP1301 LAT PULLDOWN

PRODUCT DIMENSION (L×W×H)	1703×1339×2047 (mm) 67.0×52.7×80.6 (in)
PRODUCT WEIGHT	95 kg/216.1 lbs
MAX. WEIGHT CAPACITY	200 kg/440.9 lbs



IFP1302 SEATED ROW

PRODUCT DIMENSION (L×W×H)	1470×1020×1340 (mm) 57.9×40.2×52.8 (in)
PRODUCT WEIGHT	77.5 kg/170.9 lbs
MAX. WEIGHT CAPACITY	200 kg/440.9 lbs

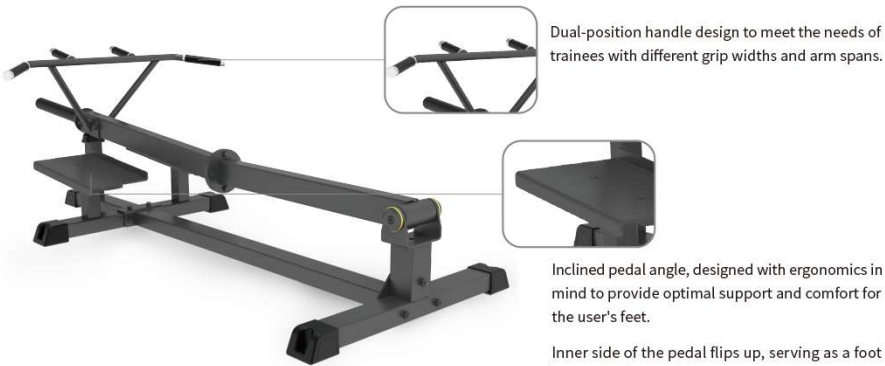

IFP1305 T-BAR ROW

PRODUCT DIMENSION (L×W×H)	2079×908×635 (mm) 81.9×35.7×25.0 (in)
PRODUCT WEIGHT	23 kg/50.7 lbs
MAX. WEIGHT CAPACITY	150 kg/330.7 lbs

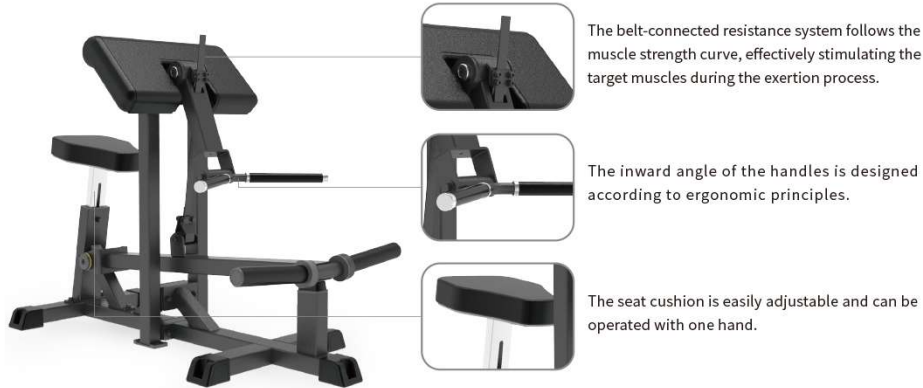

IFP1501 BICEP CURL

PRODUCT DIMENSION (L×W×H)	1302×707×988 (mm) 51.3×27.8×38.9 (in)
PRODUCT WEIGHT	56 kg/123.5 lbs
MAX. WEIGHT CAPACITY	200 kg/440.9 lbs



IFP1604 PRONE LEG CURL

PRODUCT DIMENSION (L×W×H)	1623×1202×798 (mm) 63.9×47.3×31.4 (in)
PRODUCT WEIGHT	75.9 kg/167.3 lbs
MAX. WEIGHT CAPACITY	150 kg/330.7 lbs



IFP1605 SEATED LEG EXTENSION

PRODUCT DIMENSION (L×W×H)	1246×1173×995 (mm) 49.1×46.2×39.2 (in)
PRODUCT WEIGHT	63.4 kg/139.8 lbs
MAX. WEIGHT CAPACITY	150 kg/330.7 lbs



Equipped with starting handle, the position is convenient for users to operate, safe and reliable.

Multi-level safety limit provides multiple starting positions to meet the needs of users of different heights.



There are handles at the bottom and next to the foot pedal, which are convenient for users to get on and off the machine.



The back pad is angled to fit the angle of the body during the kick to avoid excessive backward pelvis.

IFP1613 VERTICAL LEG PRESS

PRODUCT DIMENSION (L×W×H)	1655×1214×1711 (mm) 65.2×47.8×67.4 (in)
PRODUCT WEIGHT	110.4 kg/243.4 lbs
MAX. WEIGHT CAPACITY	350 kg/771.6 lbs



The height of the leg pad can be adjusted for easy user access to the machine.

The leg pad can be adjusted both forward and backward, accommodating users of different heights and leg lengths.



The pedal angle is inclined and coated with non-slip paint.



Elastic band attachment points allow for maximum stimulation of the target muscle groups without loss of tension at the end of the range of motion.

IFP1616 VERTICAL HIP THRUST

PRODUCT DIMENSION (L×W×H)	1220×1098×1165 (mm) 48.0×43.2×45.9 (in)
PRODUCT WEIGHT	67.5 kg/148.8 lbs
MAX. WEIGHT CAPACITY	150 kg/330.7 lbs



Fixed armrests, users can hold on to stabilize the core muscles during training, and focus more on lower limbs.



The starting handle with the spring can automatically spring back after starting, providing convenience for users.

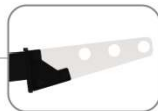

Multiple belt hanging points to meet the needs of users of different heights.



Equipped with fast buckle belt, easy for users to get on and off the machine.

IFP1615 BELT SQUAT

PRODUCT DIMENSION (L×W×H)	1615×1250×1032 (mm) 63.6×49.2×40.6 (in)
PRODUCT WEIGHT	77.5kg/170.9 lbs
MAX. WEIGHT CAPACITY	350 kg/771.6 lbs



The back pad is divided into two pieces and is interlocked at an angle to better fit the user's back, which is ergonomic and provides enough support for the user's back.

Meanwhile, the split back pad design is convenient for later maintenance and replacement.



The safety limit has two adjustable levels to meet the needs of users of different heights.



IFP1617 HACK SQUAT

PRODUCT DIMENSION (L×W×H)	1982×1485×1318 (mm) 78.0×58.5×51.9 (in)
PRODUCT WEIGHT	100.6 kg/221.8 lbs
MAX. WEIGHT CAPACITY	350 kg/771.6 lbs



The elbow pad sinks down, conforming to ergonomic design principles.

Equipped with foot pedals for easy user access to and from the machine.

Soft wrist straps distribute force evenly on the ankles, reducing pressure sensation.

IFP1619 REVERSE HYPEREXTENSION

PRODUCT DIMENSION (L×W×H)	1310×797×1153 (mm) 51.6×31.4×45.4 (in)
PRODUCT WEIGHT	66 kg/145.5 lbs
MAX. WEIGHT CAPACITY	100 kg/220.5 lbs



It can perform standing abductor and sitting abductor training, and the fixed armrest can help users maintain body balance during sitting abductor training.

Extended leg pads to meet the needs of users of different heights.

The foot pedals have anti-slip textures and the edges are cuffed to protect the user's feet from slipping and falling out.

Equipped with auxiliary pedals, which is convenient for users to get on and off the machine.

IFP1622 STANDING HIP ABDUCTOR

PRODUCT DIMENSION (L×W×H)	1720×595×1280 (mm) 67.7×23.4×50.4 (in)
PRODUCT WEIGHT	83.9kg/185.0 lbs
MAX. WEIGHT CAPACITY	150 kg/330.7 lbs



The length and shape of the seat cushion are ergonomic.

The height of the leg pads can be adjusted to meet the needs of users of different heights.

The leg pads can swing back and forth slightly to enhance user comfort.

IFP1623 SEATED CALF RAISE

PRODUCT DIMENSION (L×W×H)	1368×566×849 (mm) 53.9×22.3×33.4 (in)
PRODUCT WEIGHT	38.5kg/84.9 lbs
MAX. WEIGHT CAPACITY	100 kg/220.5 lbs



Standard with short bar for bicep curl training.

The angle of the back pad is inclined to give the user enough back support.

The height of the seat cushion is adjusted by the tooth plate, and it automatically rebounds with the back spring, which is more convenient to adjust and can be operated with one hand.

IFP1706 BICEPS/TRICEPS

PRODUCT DIMENSION (L×W×H)	1092×708×1287 (mm) 43.0×27.9×50.7 (in)
PRODUCT WEIGHT	47.3 kg/104.3 lbs
MAX. WEIGHT CAPACITY	200 kg/440.9 lbs



The shoulder pads are rounded and ergonomically designed to make the user's shoulders fit better.

Double-angled shoulder pads prevent the user's shoulders from sliding on the shoulder pads.



The starting handle cooperates with the spring to automatically rebound. After the user starts, the middle support structure automatically rebounds and is still within the controllable range of the user's hand.



The starting height can be adjusted to meet the needs of users of different heights.

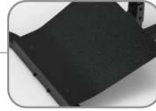

The pedals are bent for calf training.

IFP1707 LEVERAGE SQUAT/CALF

PRODUCT DIMENSION (L×W×H)	1490×1445×1550 (mm) 58.7×56.9×61.0 (in)
PRODUCT WEIGHT	115.5 kg/254.6 lbs
MAX. WEIGHT CAPACITY	350 kg/771.6 lbs



Both the foot pedal and shoulder pads can be folded and retracted with one hand to provide convenience for the user to switch between the Hack squat and reverse leg press functions.

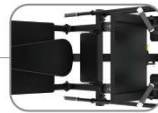

The safety handles are easily accessible on both sides, which ensure the safety during use.



The foot pedal angle adjustment can be operated with one hand, which is convenient for users to adjust.

IFP1711 HACK SQUAT/LEG PRESS

PRODUCT DIMENSION (L×W×H)	2634×1020×1373 (mm) 103.7×40.2×54.1 (in)
PRODUCT WEIGHT	150.5 kg/331.8 lbs
MAX. WEIGHT CAPACITY	350 kg/771.6 lbs



Multi-functional equipment, equipped with multiple-position pull-up handles to meet the user's needs for different exercises.



Smith machine with multiple attachment points, allowing users to start and stop the training at any height.

Equipped with smith machine safety stops to protect users from injuries due to bar disengagement.

Rail travel range accommodates floor exercises such as bent-over rows, deadlifts, and hip thrusts.

Front-side equipped with squat safety hooks and safety stops, meeting the user's training needs for free-weight squats.

IFP1721 HALF CAGE/SMITH MACHINE

PRODUCT DIMENSION (L×W×H)	1404×1850×2343 (mm) 55.3×72.8×92.2 (in)
PRODUCT WEIGHT	77.5 kg/170.9 lbs
MAX. WEIGHT CAPACITY	250 kg/551.2 lbs



Dual-function attachments for high pulldown and seated row exercises, meeting the user's need for versatile training options.

Equipped with handle hooks as standard.

IFP1721OPT LAT PULLDOWN SEATED ROW ATTACHMENT

PRODUCT DIMENSION (L×W×H)	1451×1231×2307 (mm) 57.1×48.5×90.8 (in)
PRODUCT WEIGHT	38.6 kg/85.1 lbs
MAX. WEIGHT CAPACITY	200 kg/440.9 lbs



IT7001 SMITH

PRODUCT DIMENSION (L×W×H)	2241×1326×2370 (mm) 88.2×52.2×93.3 (in)
PRODUCT WEIGHT	178 kg / 392 lbs
40'	58 Sets
MAX. WEIGHT CAPACITY	200 kg / 440 lbs



IT7002 SEATED PREACHER CURL

PRODUCT DIMENSION (L×W×H)	919×803×882 (mm) 36.2×31.6×34.7 (in)
PRODUCT WEIGHT	41 kg / 90 lbs
40'	260 Sets



IT7004 STRETCH

PRODUCT DIMENSION (L×W×H)	1274×552×997 (mm) 50.2×21.7×39.3 (in)
PRODUCT WEIGHT	35 kg / 77 lbs
40'	280 Sets



IT7005 SEATED CALF RAISE

PRODUCT DIMENSION (L×W×H)	1356×751×831 (mm) 53.4×29.6×32.7 (in)
PRODUCT WEIGHT	50 kg / 110 lbs
40'	297 Sets
MAX. WEIGHT CAPACITY	100 kg / 220 lbs



* COLOR OPTIONAL.



IT7003 AB BENCH

PRODUCT DIMENSION (L×W×H)	1745×936×997 (mm) 68.7×36.9×39.3 (in)
PRODUCT WEIGHT	57 kg / 126 lbs
40'	110 Sets



IT7006 LEG PRESS/HACK SQUAT

PRODUCT DIMENSION (L×W×H)	2253×975×1475 (mm) 88.7×38.4×58.1 (in)
PRODUCT WEIGHT	166.3 kg / 367 lbs
40'	66 Sets
MAX. WEIGHT CAPACITY	200 kg / 440 lbs



IT7007 MULTI HYPEREXTENSION

PRODUCT DIMENSION (L×W×H)	1312×749×814 (mm) 51.7×29.5×32 (in)
PRODUCT WEIGHT	43.5 kg / 96 lbs
40'	231 Sets



IT7019 INCLINE ROW

PRODUCT DIMENSION (L×W×H)	1965×1009×1262 (mm) 77.4×39.7×49.7 (in)
PRODUCT WEIGHT	77.5 kg / 171 lbs
40'	140 Sets
MAX. WEIGHT CAPACITY	150 kg / 330 lbs



IT7020 45 LEG PRESS

PRODUCT DIMENSION (L×W×H)	2199×1016×1494 (mm) 86.6×40×58.8 (in)
PRODUCT WEIGHT	140.5 kg / 310 lbs
40'	71 Sets
MAX. WEIGHT CAPACITY	200 kg / 440 lbs



IT7014 FLAT BENCH PRESS

PRODUCT DIMENSION (L×W×H)	1657×1658×1373 (mm) 65.2×65.3×54.1 (in)
PRODUCT WEIGHT	82 kg / 181 lbs
40'	126 Sets



IT7014OPT SPOTTER STAND

PRODUCT DIMENSION (L×W×H)	661×442×262 (mm) 26.0×17.4×10.3 (in)
PRODUCT WEIGHT	25.1 kg/55.2 lbs
40'	680 Sets



IT7010 VERTICAL KNEE RAISE

PRODUCT DIMENSION (L×W×H)	1131×781×1515 (mm) 44.5×30.7×59.6 (in)
PRODUCT WEIGHT	53 kg / 117 lbs
40'	160 Sets



IT7010EOPT CHIN-UP ATTACHMENT

DIMENSION (L×W×H)	2299×930×660 (mm) 90.5×36.6×26 (in)
PRODUCT WEIGHT	30.5kg/67.3lbs



IT7015 INCLINE BENCH PRESS

PRODUCT DIMENSION (L×W×H)	1632×1658×1373 (mm) 64.3×65.3×54.1 (in)
PRODUCT WEIGHT	106.5 kg / 235 lbs
40'	112 Sets



IT7016 DECLINE BENCH PRESS

PRODUCT DIMENSION (L×W×H)	2103×1658×1370 (mm) 82.8×65.3×53.9 (in)
PRODUCT WEIGHT	87 kg / 192 lbs
40'	126 Sets



IT7013 MULTI AB BENCH

PRODUCT DIMENSION (L×W×H)	1738×725×899 (mm) 68.4×28.5×35.4 (in)
PRODUCT WEIGHT 40'	42.5 kg / 94 lbs 140 Sets



IT7009 FLAT BENCH

PRODUCT DIMENSION (L×W×H)	1200×748.6×426(mm) 47.2×29.5×16.8 (in)
PRODUCT WEIGHT 40'	27.5 kg / 61 lbs 220 Sets



IT7011 MULTI-ADJUSTABLE BENCH

PRODUCT DIMENSION (L×W×H)	1212×750×465 (mm) 47.7×29.5×18.3 (in)
PRODUCT WEIGHT 40'	40 kg / 88 lbs 207 Sets



IT7022 UTILITY BENCH

PRODUCT DIMENSION (L×W×H)	1165×603×818 (mm) 45.9×23.7×32.2 (in)
PRODUCT WEIGHT 40'	21.3 kg / 47 lbs 308 Sets



IT7030 ROMAN CHAIR

DIMENSION (L×W×H)	985×726×625 (mm) 38.8×28.6×24.6 (in)
PRODUCT WEIGHT	35kg/77.2lbs

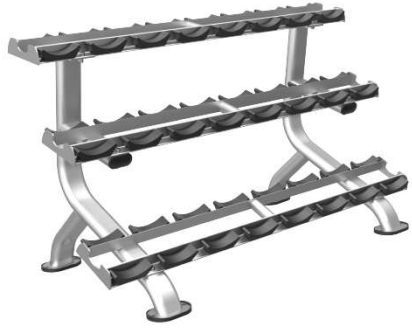

IT7012 DUMBBELL RACK

PRODUCT DIMENSION (L×W×H)	1508×814×938(mm) 59.4×32.0×36.9(in)
PRODUCT WEIGHT	71kg/156lbs
40'	140Sets



IT7018 DUMBBELL RACK

PRODUCT DIMENSION (L×W×H)	1580×814×982 (mm) 62.2×32×38.7 (in)
40'	140 Sets



IT7031 SHOULDER BENCH PRESS

DIMENSION (L×W×H)	1349×1126×1651(mm) 53.1×44.3×65(in)
PRODUCT WEIGHT	86.5 kg/190.9 lbs
MAX. WEIGHT CAPACITY	300 kg/660 lbs



IT7017 WEIGHT PLATE TREE

PRODUCT DIMENSION (L×W×H)	950×610×1220 (mm) 37.4×24×48 (in)
PRODUCT WEIGHT	26 kg / 57 lbs
40'	264 Sets



IT7027 BARBELL RACK

PRODUCT DIMENSION (L×W×H)	919×907×1612 (mm) 36.2×35.7×63.5 (in)
PRODUCT WEIGHT	68 kg / 150 lbs
40'	112 Sets



IT7032 OLYMPIC BAR RACK

DIMENSION (L×W×H)	960×710×1086(mm) 37.8×28×42.8(in)
PRODUCT WEIGHT	47 kg/103.7 lbs
MAX. WEIGHT CAPACITY	300 kg/660 lbs

IT7033 MAX RACK

DIMENSION (L×W×H)	2000×1410×2185(mm) 78.7×55.5×86(in)
PRODUCT WEIGHT	199.4 kg/440 lbs
MAX. WEIGHT CAPACITY	200 kg/440 lbs





IFHC
HALF CAGE

PRODUCT DIMENSION (L×W×H)	1681×1720×2090 (mm) 66.2×67.7×82.3 (in)
PRODUCT WEIGHT	100 kg / 221 lbs
40'	150 Sets



IFHCL
HALF CAGE LAT ATTACHMENT

PRODUCT DIMENSION (L×W×H)	1800×400×2100 (mm) 70.9×15.7×82.7 (in)
PRODUCT WEIGHT	41 kg / 90 lbs
40'	234 Sets

IFHCS
HALF CAGE SMITH ATTACHMENT

PRODUCT DIMENSION (L×W×H)	1946×300×1727 (mm) 76.6×11.8×68 (in)
PRODUCT WEIGHT	33 kg / 73 lbs
40'	425 Sets
MAX. WEIGHT CAPACITY	200 kg / 440 lbs



IFLATM
LAT MACHINE

PRODUCT DIMENSION (L×W×H)	1452×1224×2129 (mm) 57.2×48.2×83.8 (in)
PRODUCT WEIGHT	55.5 kg / 122 lbs
40'	302 Sets



IFPC
POWER CAGE

PRODUCT DIMENSION (L×W×H)	1576×1256×2149 (mm) 62.0×49.4×84.6 (in)
PRODUCT WEIGHT	114 kg / 251 lbs
40'	90 Sets

IFPCL
POWER CAGE LAT ATTACHMENT

PRODUCT DIMENSION (L×W×H)	1212×945×2053 (mm) 47.7×37.2×80.8 (in)
PRODUCT WEIGHT	31.8 kg / 70 lbs
40'	420 Sets





**IF45 45-DEGREE
HYPEREXTENSION**

PRODUCT DIMENSION (L×W×H)	1224×743×739 (mm) 48.2×29.3×29.1 (in)
PRODUCT WEIGHT	23.5 kg / 52 lbs
40'	340 Sets



**IFAH ADJUSTABLE
HYPEREXTENSION BENCH**

PRODUCT DIMENSION (L×W×H)	1260×743×917 (mm) 49.6×29.3×36.1 (in)
PRODUCT WEIGHT	36 kg / 79 lbs
40'	360 Sets



**IFRC
ROMAN CHAIR**

PRODUCT DIMENSION (L×W×H)	1361×743×1091 (mm) 53.6×29.3×43 (in)
PRODUCT WEIGHT	30.5 kg / 67 lbs
40'	504 Sets



**IFFB
FLAT BENCH**

PRODUCT DIMENSION (L×W×H)	1303×526×490 (mm) 51.3×20.7×19.3 (in)
PRODUCT WEIGHT	19.5 kg / 43 lbs
40'	532 Sets



**IFUB
UTILITY BENCH**

PRODUCT DIMENSION (L×W×H)	862×596×874 (mm) 33.9×23.5×34.4 (in)
PRODUCT WEIGHT	12.7 kg / 28 lbs
40'	375 Sets



**IFFI
FLAT/INCLINE BENCH**

PRODUCT DIMENSION (L×W×H)	1603×654×498 (mm) 63.1×25.7×19.6 (in)
PRODUCT WEIGHT	30 kg / 66 lbs
40'	396 Sets



**IFSPC SEATED
PREACHER CURL**

PRODUCT DIMENSION (L×W×H)	1021×712×870 (mm) 40.2×28×34.3 (in)
PRODUCT WEIGHT	24.7 kg / 54 lbs
40'	420 Sets



**IFAAB ADJUSTABLE
ABDOMINAL BENCH**

PRODUCT DIMENSION (L×W×H)	1624×570×1115 (mm) 63.9×22.4×43.9 (in)
PRODUCT WEIGHT	24 kg / 53 lbs
40'	450 Sets



**IFAC
ABDOMINAL CRUNCH**

PRODUCT DIMENSION (L×W×H)	1103×476×578 (mm) 43.4×18.7×22.8 (in)
PRODUCT WEIGHT	17 kg / 37 lbs
40'	697 Sets



**IFOB
OLYMPIC BENCH PRESS**

PRODUCT DIMENSION (L×W×H)	1439×1264×1086 (mm) 56.7×49.8×42.8 (in)
PRODUCT WEIGHT	62.5 kg / 138 lbs
40'	252 Sets



**IFARMA
ARM CURL ATTACHMENT**

PRODUCT DIMENSION (L×W×H)	584×434×761 (mm) 23×17.1×30 (in)
PRODUCT WEIGHT	6.6 kg / 15 lbs
40'	840 Sets



**IFLEGA
LEG EXTENSION/CURL ATTACHMENT**

PRODUCT DIMENSION (L×W×H)	539×426×470 (mm) 21.2×16.8×18.5 (in)
PRODUCT WEIGHT	7.3 kg / 16 lbs
40'	1728 Sets

STRENGTH

IF



**IFSTF
STRETCH**

PRODUCT DIMENSION (L×W×H)	1865×1730×2150 (mm) 73.4×68.1×84.6 (in)
PRODUCT WEIGHT	90 kg / 198 lbs
40'	112 Sets



**IFPT
POWER TOWER**

PRODUCT DIMENSION (L×W×H)	1242×1316×2113 (mm) 48.9×51.8×83.2 (in)
PRODUCT WEIGHT	76.5 kg / 169 lbs
40'	245 Sets

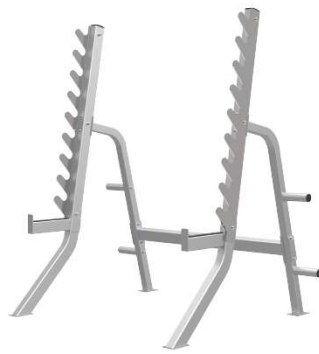

**IFSS
SQUAT STAND**

PRODUCT DIMENSION (L×W×H)	1226×1575×1735 (mm) 48.3×62×68.3 (in)
PRODUCT WEIGHT	56.5 kg / 125 lbs
40'	320 Sets



**IFOFB
FLAT BENCH PRESS**

PRODUCT DIMENSION (L×W×H)	1525×1310×1265 (mm) 60×51.6×49.8 (in)
PRODUCT WEIGHT	60.5 kg / 133 lbs
40'	154 Sets



**IFOIB
INCLINE BENCH PRESS**

PRODUCT DIMENSION (L×W×H)	1560×1310×1395 (mm) 61.4×51.6×54.9 (in)
PRODUCT WEIGHT	68.5 kg / 151 lbs
40'	147 Sets

STRENGTH

IF



**IFLPHS
LEG PRESS/HACK SQUAT MACHINE**

PRODUCT DIMENSION (L×W×H)	2245×818×1298 (mm) 88.4×32.2×51.1 (in)
PRODUCT WEIGHT	162.5 kg / 358 lbs
40'	108 Sets
MAX. WEIGHT CAPACITY	200 kg / 440 lbs



**IFFID
MULTI-PURPOSE BENCH**

PRODUCT DIMENSION (L×W×H)	1582×655×501 (mm) 62.3×25.8×19.7 (in)
PRODUCT WEIGHT	33 kg / 73 lbs
40'	417 Sets



**IFODB
DECLINE BENCH PRESS**

PRODUCT DIMENSION (L×W×H)	1900×1310×1156 (mm) 74.8×51.6×45.5 (in)
PRODUCT WEIGHT	70 kg / 154 lbs
40'	154 Sets



STRENGTH

IF



IFLEGM
LEG EXTENSION/CURL MACHINE

PRODUCT DIMENSION (L×W×H)	1055×1044×1053 (mm) 41.5×41.1×41.5 (in)
PRODUCT WEIGHT	51 kg / 112 lbs
40'	192 Sets



IFCR
CALF RAISE

PRODUCT DIMENSION (L×W×H)	1207×559×1016 (mm) 43.3×22.0×40.0 (in)
PRODUCT WEIGHT	47.5 kg / 78 lbs
40'	520 Sets
MAX. WEIGHT CAPACITY	100 kg / 220 lbs



IFBR
BARBELL RACK

PRODUCT DIMENSION (L×W×H)	792×844×1380 (mm) 31.2×33.2×54.3 (in)
PRODUCT WEIGHT	43.7 kg / 96 lbs
40'	195 Sets



IFPTO
PLATE TREE-OLYMPIC

PRODUCT DIMENSION (L×W×H)	843×632×1108 (mm) 33.2×24.9×43.6 (in)
PRODUCT WEIGHT	19.5 kg / 43 lbs
40'	890 Sets

STRENGTH

IF



IFDB3
DUMBBELL RACK-3'

PRODUCT DIMENSION (L×W×H)	1079×473×677 (mm) 42.5×18.6×26.7 (in)
PRODUCT WEIGHT	29 kg / 64 lbs
40'	600 Sets



IFDB4
DUMBBELL RACK-4'

PRODUCT DIMENSION (L×W×H)	1372×475×869 (mm) 54×18.7×34.2 (in)
PRODUCT WEIGHT	35.3 kg / 78 lbs
40'	430 Sets



IFDB4A
DUMBBELL RACK-4' ATTACHMENT

PRODUCT DIMENSION (L×W×H)	1242×244×74 (mm) 48.9×9.6×2.9 (in)
PRODUCT WEIGHT	12 kg / 26 lbs
40'	1400 Sets



Impulse Cardiovascular Equipment Limited Warranty

Description	Warranty
Frame	7 Years
Treadmill AC Motor	3 Years
Treadmill DC Motor, Structural Moving Parts	2 Years
Display PCB, Motor Controller,	
Generator, EMS, ECB Brake	2 Years
Key Pad, Durable Wear Parts	1 Year

Impulse Strength Training Equipment Limited Warranty

Description	Warranty
Structural Steel Frame	Lifetime
Rotary Bearings, Weight Stacks, Pulleys,	
Guide Rods, Structural Moving Parts	2 Years
Cable, Linear Bearings, Springs	1 Year
Upholstery, Handgrips, All Other	
Items Not Listed	6 Months

* Conditions and Restrictions Applied.



im impulse

THE WAY TO WELLNESS

www.impulse-fitness.kz

All text, picture and data in this catalogue are for reference only. If there is inconsistency between the information and the actual product, the actual product shall govern. Impulse reserves all rights to explain any error or difference in this catalogue.

The trademark property in copyright including "Siegling", "Wahoo" and "Polar" have been mentioned in Impulse product catalogues belong to their respective trademark registers.

Statement: Impulse branding is upgrading and during that time, **im**, **impulse** and **impulse** are both trademarks of Impulse products. Thank you for your support as always.